

AUTO INJECTOR SYSTEM

AVIATION INJECTOR SYSTEM

ROCKET ENGINES APPLICATIONS

# Water Fuel Cell

## International Independent Test-Evaluation Report

Water Fuel Cell  
WFC Dealership Marketing Prospectus  
Copyright © 1995 By Stanley A. Meyer  
© under UCC 1979 By Stanley A. Meyer

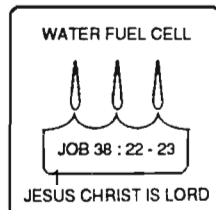

AUTO INJECTOR SYSTEM

AVIATION INJECTOR SYSTEM

ROCKET ENGINES APPLICATIONS

# Water Fuel Cell

## International Independent Test-Evaluation Report

Water Fuel Cell  
WFC Dealership Marketing Prospectus  
Copyright © 1995 By Stanley A. Meyer  
© under UCC 1979 By Stanley A. Meyer

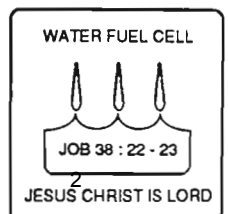

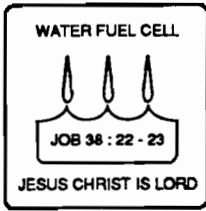

# WATER FUEL CELL

## *The Birth of New Technology*

### *WFC International Independent Test-Evaluation Report*

#### Notice of Technology

All Rights Reserved

Printed in the United States of America. Except in the case of brief quotations embodied in critical articles or review, no part of this WFC technical brief may be reproduce in any form or by any means, or stored in a databank or retrieval system without express written permission of inventor Stanley A. Meyer. For written approval, fax (614) 871-8075 or send request to 3792 Broadway, Grove City, Ohio 43123.

All graphic illustrations were created and registered under international UCC copyright laws by Stanley A. Meyer

All publishing rights reserved by Stanley A. Meyer under international UCC copyright laws.

\*\*\*\*\*

#### National Security Laws

Patent security is enforced by National security Laws of each participating country. Do "not" make, sell, or utilize a patented process and/or device without inventor written consent and approval. International patent and copyright laws mandate the same "usage" restrictions.

Information presented in this manual is not to be used for manufacturing purposes.

\*\*\*\*\*

#### Foreign Grant License

The U.S. Government has allowed the WFC technology to go forward into the international market place by issuing foreign grant license No. 492680 issued July 10, 1989 and foreign grant license No. 490606 issued Nov. 15, 1989 to Stanley A. Meyer as so specified and required under the Patent Cooperation Treaty (PCT) Act. Heavy fines and imprisonment are levied on anyone who falsely claims to have participated in the development of a invention. Under the PCT Act, a Declaration of Oath must be signed, certified, and registered prior to the filing of any PCT patent application.

\*\*\*\*\*

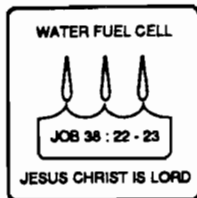

# WATER FUEL CELL

## *The Birth of New Technology*

### *WFC International Independent Test-Evaluation Report*

---

#### Patents Granted To Date

Stanley A. Meyer

---

4,389,981	Hydrogen gas injector system for internal combustion engine (U.S.A.)
4,613,779	Electrical pulse generator (U.S.A.)
4,421,474	Hydrogen gas burner (U.S.A.)
1,231,872	Hydrogen injector system (CDA)
1,233,379	Hydrogen gas injector for internal combustion engine (CDA)
1,228,833	Gas electrical hydrogen generator (CDA)
1,227,094	Hydrogen/air & non-combustible gas mixing combustionsystem (CDA)
4,613,304	Gas electrical hydrogen generator (USA)
1,235,669	Controlled hydrogen gas flame (CDA)
4,275,950	Light-guide lens (USA)
1,234,774	Hydrogen generator system (USA)
3,970,070	Solar heating system (USA)
1,234,773	Resonant cavity hydrogen generator that operates with a pulse voltage electrical potential (CDA)
4,265,224	Multi-stage solar storage system (USA)
1,213,671	Electrical particle generator (CDA)
4,465,455	Start-up / shut-down for a hydrogen gas burner (USA)
4,798,661	Gas generator voltage control circuit (USA)
4,826,581	Controlled process for the production of thermal energy from gases and apparatus useful therefore (Hydrogen Fracturin Process) (PCT)
5,149,407	Process and apparatus for the production of fuel gas and the enhanced release of thermal energy from such gas (Electronic interfacing for the Hydrogen Fracturing Process) (Resonant Action) (USA) (WFC Project 423 DA)
0101761	Controlled hydrogen gas flame (EPO)
1577992	Controlled hydrogen Gas flame (JPO)
0086439	Hydrogen gas injector system for internal combustion engine (EPO)
1584224	Hydrogen Injection System (JPO)
4,936,961	Method For the production of a Fuel Gas "Electrical Polarization Process" (U.S.A.)
1,694,782	Resonant Cavity For Hydrogen Generator (JPO)
5,293,857	Hydrogen gas fuel and management system for an internal combustion engine utilizing hydrogen gas fuel (U.S.A.)

#### Other U.S. & Foreign Patents Pending

*Refer to WFC Profit Sharing Certificate Prospectus when considering  
purchasing a WFC Dealership or obtaining a WFC Profit Sharing Certificate*

## Water Fuel Cell

### International Independent Test-Evaluation Report

#### Purpose of Content

It has taken Water Fuel Cell (WFC) since before 1985 to have the "Scientific Community" to "concur" that the water molecule is in fact bipolar electrically charged as so related in WFC Tech-Brief titled "The Birth of New Technology", that there is an electrical attraction force ( $qq'$ ) between the opposite charged atoms of the water molecule, that no electromagnetic force exist between the unlike atoms of the water molecule since the oxygen atom "L" orbital eight electrons pair together and spin in opposite directions, that the "L" orbit of the oxygen atom only accepts up to but no more than eight (8) electrons ... stabilizing the existence of the water molecule ... establishing the dielectric value of water as being  $78.54 \Omega$ , that the electrical attraction force ( $qq'$ ) electrical intensity is equivalent to the two shared hydrogen electrons occupying the outer "L" orbit of the negative charged oxygen atom, that applied Voltage Potential during pulsing operations is not consumed in an electronic circuit, that "Electrical Stress" of opposite electrical polarity does in fact encourage "Particle Oscillation" as a "Energy Generator", that an external "Electrical Attraction Force" ( $SS' \approx RR'$ ) exposed to the water molecule is all that is required to dissociates the water molecule by "Electrical Stress" set forth by "opposite voltage fields", and that water droplets can be instantly converted into thermal explosive energy (gtnt) at higher voltage levels, as so related by the many Scientific Journal Reports produced by both Governmental and University Test-Labs around the World and which are, herein, in-part affixed to said WFC International Independent Test-Evaluation Report-manual for scientific review.

**A Critical Review of the Available Information Regarding Claims of  
Zero-Point Energy, Free-Energy, and Over-Unity Experiments and Devices**

by

Patrick G. Bailey  
P.O. Box 201  
Los Altos, CA 94023-0201

and

Toby Grotz  
760 Prairie Avenue  
Craig, CO 81625-1346

Reprinted From:

28th Intersociety Energy Conversion Engineering Conference  
28th IECEC  
August 8-13, 1993  
Atlanta, Georgia

28th IECEC Conference Proceedings  
Volume 2  
Pages 2.905-2.910  
ISBN 0-8412-2772-5

Reprinted with Permission

**Taken From: INSIGHTS INTO THE PROPRIETARY SYNDROME**

By KEN MacNEILL

Cadake Industries, P.O. Box 1866, Clayton, GA 30525

**PART I**

Consider your receiving this:

**SECURITY ORDER**

**(Title 35, United States Code (1952), sections 181-188)**

**NOTICE:** To the applicant above named, his heirs, and any and all of his assignees, attorneys and agents, hereinafter designated principals:

You are hereby notified that your application as above identified has been found to contain subject matter, the unauthorized disclosure of which might be detrimental to the national security, and you are ordered in nowise to publish or disclose the invention or any material information with respect thereto, including hitherto unpublished details of the subject matter of said application, in any way to any person not cognizant of the invention prior to the date of the order, including any employee of the principals, but to keep the same secret except by written consent first obtained of the Commissioner of Patents, under the penalties of 35 U.S.C. (1952) 182, 186.

Any other application already filed or hereafter filed which contains any significant part of the subject matter of the above identified application falls within the scope of this order. If such other application does not stand under a security order, it and the common subject matter should be brought to the attention of the Security Group, Licensing and Review, Patent Office.

If, prior to the issuance of the secrecy order, any significant part of the subject matter has been revealed to any person, the principals shall promptly inform such person of the secrecy order and the penalties for improper disclosure. However, if such part of the subject matter was disclosed to any person in a foreign country or foreign national in the U.S., the principals shall not inform such person of the secrecy order, but instead shall promptly furnish to the Commissioner of Patents the following information to the extent not already furnished: date of disclosure; name and address of the disclosee; identification of such part; and any authorization by a U.S. government agency to export such part. If the subject matter is included in any foreign patent application, or patent, this should be identified. The principals shall comply with any related instructions of the Commissioner.

This order should not be construed in any way to mean that the Government has adopted or contemplates adoption of the alleged invention disclosed in this application; nor is it any indication of the value of such invention.

Transcribed from: PROCEEDINGS: The Second International Symposium on Non-Conventional Energy Technology, pp 125-126. I was told this was presented on September 23, 1983. I also have a copy of a real one dated March 17, 1964, that was sent to a friend of mine who had applied for a patent in the field of space energy research.

# A Critical Review of the Available Information Regarding Claims of Zero-Point Energy, Free-Energy, and Over-Unity Experiments and Devices

Patrick G. Bailey  
P.O. Box 201  
Los Altos, CA 94023-0201

Toby Grotz  
760 Prairie Avenue  
Craig, CO 81625-1346

## Abstract

A summary review is presented of the experiments, motors, generators, devices, and demonstrations that have been reported in the past few years to produce near-unity or over-unity operation. The concepts of free-energy, zero-point energy, and over-unity devices are not new, and many examples of such devices have been built within the last 100 years. 26 researchers are reviewed and 11 are selected for immediate interest and support. Whether a new form of potential energy can be demonstrated and successfully utilized within the near future for the ultimate benefit of the human race remains to be seen.

## Definitions

'Energy' cannot be created nor destroyed - it exists throughout space and within matter. 'Perpetual Motion' does not exist - long lasting motion is easily observable, such as planetary orbits. 'Stupidity' is not hereditary - and it is not a survival trait.

'Zero-Point Energy' (ZPE) is known as an energy that fills the fabric of all space. Technically the ZPE results from an electric flux that flows orthogonally to our perceived dimension or reality. The mass equivalence of this energy has been calculated by physicists to be on the order of  $1093 \text{ gms/cm}^3$ . Henry T. Moray, Walter Russell, and Nikola Tesla described the nature of the ZPE and designed and built equipment to engineer its properties. It may be possible to build devices to cohere this energy. This would result in a non-polluting, unlimited supply of virtually free energy.

'Free Energy' is a term that can have two meanings: either the additional energy that can be obtained from a device at little or no additional cost, so the additional energy is essentially free; or more output energy that appears to be available than input energy, such as in the case of detonating an atomic bomb.

'Over-unity Devices' are those systems which appear to produce more energy than they use. In analyzing such systems, a box is drawn around the device and energy balances are formulated to measure the amounts of energy coming into and out of that box. Whether or not the device is termed an 'over-unity' device will depend upon the size of the box. When the box is drawn large enough, all systems or devices will have a net energy transfer of zero. On the other hand, when the box is drawn just small enough, the device can be said to be an 'over-unity' device, and an intelligent physicist will know better.

From this point of view, examples of existing so-called free-energy devices abound: such as Hoover Dam. So then is any generator, or any nuclear reactor. More energy certainly comes out of a dam than went in to making it (by us, at least). And any dam engineer will tell you that it will produce more energy than it cost to build and that it will last forever (or at least until his kids get out of college). So it is seen that these generators can be thought of as free-energy devices, while they are really only energy conversion devices, and obviously not perpetual motion machines. People who insist that they actually are, are either very ignorant or very devious. In such cases, examine the person's true motives. [Another 'free-energy' device of increasingly noteworthy attention is the Federal Reserve, which is not an agency of the US government. (Figgie 1992)]

## Sources of Information and Data

Ultimately, the sources for all information in these areas come from the inventors, researchers, or investigators themselves. The US and foreign patent offices provide some information into new developments in these areas, yet the actual patents reveal very little useful information and almost no experimental results. Patent law does not require complete disclosure of all data, and patents are held nationally. An interesting area of big business today is the international transfer of patents at no cost.



Other sources of information and data include papers, reports, books, and conference proceedings. Papers and books that are of special interest are those by Hans Coler (1946), the Gravity Research Group (GRG 1956), Stefan Marinov (1992), Hans Nieper (1984), and Shinichi Seike (1992). Conferences that have been recently held to collect and summarize information in these areas include the 26th and 27th Intersociety Energy Conversion Engineering Conferences (1991 and 1992) and the more recent International Symposium on New Energy (ISNE) (April 1993). All of these materials are available from the sources identified in the references section. As a result of a 1993 ISNE working group, the working devices were categorized into four distinct areas: (1) Solid-State Space-Energy Generators, (2) Rotating Space-Energy Machines, (3) Fusion Conversion Devices, and (4) Hydrogen Energy.

### Summary of Interesting Theories, Experiments, and Devices

"Some things have to be believed to be seen." <sup>1</sup>

There are several societies and conferences world-wide that present and sometimes document the results of research in these areas. As this work is not considered as mainstream science within the US, much of the results of these researchers goes by unnoticed. The 26th IECEC (1991) provided a forum for researchers in these areas to voluntarily come forward and present their ideas, theories, and results to the mainstream scientific community. They were met with interest ranging from mistrust to awe, and from feelings ranging from friendship to outright anger. The ranges of these attitudes will likely depend upon the emotional stability of the listeners.

The 26th IECEC created international interest that stimulated further review papers to be published in the later IECECs. A growing group of organizations is networking on a world-wide basis to support and organize this on-going research. Some of these organizations are listed in the references (AREI, AFS, GRI, IASA, INE, ITS, JPI, SEA, TI, and USP). "New Energy News" is the new monthly newsletter of Institute for New Energy (INE), a recently formed US technical society, created in April 1993, that is committed to researching these technical areas. Note that the references include complete and accurate address and cost information, so that serious investigators have no excuse to not investigate.

<sup>1</sup> Poltergeist, Screenplay to the MGM/UA film production and VHS videotape, 1987.

This review includes all of the information that was made available to the 1991 IECEC, the 1992 IECEC, the 1993 International Symposium on New Energy (ISNE), and other contributed personal source information and documents. Our focus here is on actual data and results - not on ideas or mathematical theories. Our emphasis here is on repeatable experimental evidence - or on the documented testimony of multiple reliable witnesses that have been willing to stand-up, testify, and document a description of what they witnessed. Just because you don't see it doesn't mean that it's not real.

The list of the researchers, experiments, devices, and results that were addressed in this review are listed in Table 1. The reference corresponding to each researcher is also listed. Videotapes were made of all ref. speakers at the 1991 IECEC and the 1993 ISNE.

### Possible Misleading Results

"But goodness alone is never enough. A hard, cold wisdom is required for goodness to accomplish good." <sup>2</sup>

We feel that the interpretation of anyone's results can fall into one of four categories: (1) Lying for attention; (2) Lying for money (funding, stock options, etc.); (3) Inaccurate measurement or misinterpretation of the data or results; and (4) Accurate representation of the physical phenomena. In our reviews, we found absolutely no evidence that any one of the researchers we studied in Table 1 belonged specifically in categories (1) or (2) (although so far as we know three of these researchers have not been able to replicate their initial published results). Frauds are quickly discovered, if encouraged to reproduce their results and to provide detailed information. So, we were left to carefully analyze the results from each researcher and to carefully draw our own conclusions.

While on one hand some researchers may possibly be overstating the capabilities and results of their experiments and devices, on the other hand many so-called 'scientific experts' are very active in discounting all of the research results in these areas without investigating the details of any of them. "The Nobel chemist Irving Langmuir (1881-1957) used to give a cautionary talk on pathological science, and ... told a number of stories of pathological science and listed the features they have

<sup>2</sup> Heinlein, Robert A., Stranger in a Strange Land, Berkley Books, 1982.

Table 1. A Listing of Researchers and their Experiments and/or Devices of Current Interest

<u>Researcher(s)</u>	<u>Experiments, Devices, and Demonstrations</u>	<u>References</u>
Adams, Robert	Adams Pulsed Motor Generator and Replication	Adams 1993
Baumann, Paul, et. al.	Methemitha Swiss M-L Converter Device Demonstrations	IECEC 1991
Bedini, John	Bedini Free Energy Generator Plans and Demonstrations	IECEC 1991
Binder, Timothy	Russell's Nuclear-Magnetic Transmutation Experiments	ISNE 1993
Brown, Paul	Nuclear Resonant Generators and Demonstrations	IECEC 1991
Coler, Hans	Magnetstromapparat and Stromerzeuger Devices / Demos.	Coler 1946
Grotz, Toby	Russell's Power Multiplication Principle Experiments	IECEC 1992, ISNE 1993
Hathaway, George	Unipolar Dynamo of Novel Construction Experiments	IECEC 1991, ISNE 1993
Hickox, Barbara	Electric Dynamo Patent	IECEC 1991
Johnson, Gary	Electrically Induced Explosions in Water Experiments	IECEC 1992
Kelly, Don	Electromagnetic Antigravity Drop Tests	ISNE 1993, SEA
Lambertson, Wingate	WIN Process	IECEC 1991
Marinov, Stefan	Venetin Coliu Generator Demonstrations	ISNE 1993
McKie, Richard	Power On Demand Module Concept (PODMOD)	IECEC 1991
Meyer, Stanley	Water Fuel Cell Demonstrations	ISNE 1993
Moray, John and Kevin	T. Henry Moray's Radiant Energy Device	IECEC 1991
Muller, William	Muller Motor/Generator	IECEC 1991
Newman, Joseph	Magnetic Fields Utilization Energy Machine	Newman 1993
dePalma, Bruce	N-Machine Experiments	IECEC 1991
Pappas, Panos	Energy Creation in Sparks and Discharges Experiments	IECEC 1991
Reed, Troy and Evelyn	Reed Magnetic Motor Experiments	IECEC 1991, ISNE 1993
Seike, Shinichi	Negative Energy and Landau Oscillator Experiments	Seike 1992
Storms, Edmund	Established Cold Fusion and Reproducible Results	IECEC 1993
Sweet, Floyd	Vacuum Triode Assembly Device Demonstrations	IECEC 1991
Tewari, Paramahansa	Space Power Generator Experiments	ISNE 1993
Valone, Thomas	Homopolar Generator Experiments	IECEC 1991, ISNE 1993

in common." (Cromer, *Skeptical Inquirer*, 1993). In his eight page article, Cromer states that there are many lessons from this: "(1) Scientists themselves are often poor judges of the scientific process; (2) Scientific research is very difficult. Anything that can go wrong will go wrong; (3) Science isn't dependent on the honesty or wisdom of scientists. (4) Real discoveries of phenomena contrary to all previous scientific experience are very rare, while fraud, fakery, foolishness, and error resulting from overenthusiasm and delusion are all too common. Thus, Glashow's closed-minded 'I don't believe a word of it' is going to be correct far more often than not." Cromer also cites Langmuir as saying (Langmuir 1989): "There are cases where there is no dishonesty involved, but where people are tricked into false results by a lack of understanding about what human beings can do to themselves in the way of being led astray by subjective effects, wishful thinking, or threshold interactions. These are examples of pathological science. These are things that attracted a great deal of attention. ... [But] the critics can't reproduce the effects. Only the supporters could do that. In the end, nothing was salvaged. Why should there be? There isn't anything there. There never was."

Our sincere response to you is: If there is no initial interest - then there will be no investigation. If there is no investigation, there will be no research to replicate. Your interest will spark the urge to replicate. If there is interest, research, and no replication, then that fact should be published and disseminated with integrity. If there are witnesses to the results and the results were or are repeatable, then we feel the fault and blame lies with the critic and not with the researcher. Therefore, given the experiments and devices referenced in this paper: Demand that they be tested with an open mind! One success out of all of the failures is more than worth the effort!

### Devices of Great Interest

"Grant shook his head. It's been discussed, in the field. Many people imagined it was coming. But not so soon." "Story of our species, Malcolm said laughing. Everybody knows it's coming, but not so soon." <sup>3</sup>

<sup>3</sup> Crichton, Michael, *Jurassic Park*, Ballantine Books, 1990.

Table 2. A Listing of Promising Devices of Great Interest with Documented Demonstrations

<u>Researcher(s)</u>	<u>Effects Observed</u>	<u>Yrs</u>	<u>Cat</u>	<u>Doc</u>	<u>MWs</u>	<u>RDs</u>	<u>Res</u>	<u>Eff</u>
Baumann, Paul et. al.	Over-Unity, Rotating, Self-Sustaining	1984+	2	Y	Y	Y	N	N
Binder, Timothy	Chemical Dependency on E-M	1927+	1	Y	Y	Y	Y	N
Coler, Hans	Gravitational Field Generator	1942+	1	Y	Y	Y	N	N
Grotz, Toby	Over-Unity, Rotational Generator	1961+	1	Y	Y	N	Y	N
Kelly, Don	E-M Field Drop Tests & Oscillators	1992+	1	Y	N	Y	Y	N
Marinov, Stefan	Anti-Lenz Effect Motor/Generator	1988+	1	Y	Y	Y	Y	N
Meyer, Stanley	Energy from Water, H <sub>2</sub> Fracturing	1980s	4	Y	Y	Y	Y	N
Moray, John and Kevin	Over-Unity, Self-Sustaining Device	1930s	1	Y	Y	Y	N	N
Storms, Edmund	Over-Unity Thermal, Cold Fusion	1990s	3	Y	Y	Y	Y	N
Sweet, Floyd	Over-Unity, Steady-Variable Device	1990s	1	Y	Y	Y	N	N
Tewari, Paramahansa	Over-Unity Rotational N-Machine	1993	2	Y	N	Y	Y	N

Key:

- Yrs Years the Effects were observed.
- Cat Categories 1 through 4, as defined under 'Sources of Information and Data.'
- Doc Documentation Exists (Yes or No) (Y/N).
- MWs Multiple Witnesses Testimony (Y/N).
- RDs Repeated Demonstrations (Y/N).
- Res Currently Being Researched (Y/N).
- Eff Large Research Effort (Y/N).

The researchers and the works that we feel are worthy of great attention in the near future are those that are listed in Table 2. It should be noted that some researchers have been omitted from Table 2 only because either their work is of a proprietary or confidential nature, or because we could not obtain the required data or documentation from witnesses. Such researchers include: Paul Brown, Bruce dePalma, and the Reeds. All of the researchers listed in Table 1 and not listed in Table 2 have provided and we trust will continue to provide important contributions to and documentation of their work. In fact, some of this work may be turn out to be more important than those currently listed in Table 2. However, at the present moment of time as this paper is being written, we considered those devices listed in Table 2 to be of the greatest interest to us.

**Summary Information and Data**

The Methernitha Swiss M-L Converter developed by Paul Baumann and the Methernitha spiritual community in Switzerland has been repeatedly demonstrated to many scientists upon request (26th IECEC, Nieper 1984, SEA). Its three foot counter-rotating disks and specially designed energy storage system are reported to generate a steady output power of about 3 to 5 kilo-Watts (kW) indefinitely - while sitting on top of a table. A videotape has been produced and its narration has been transcribed.

Tim Binder and his team have replicated the 1927 experiments of Walter Russell and have created fluorine from pure water vapor using complex E-M field arrangements. This work validates Russell's theories about nuclear structure and the proper arrangement of the Periodic Table of the Elements.

Hans Coler demonstrated two major devices to many amazed witnesses and officials in Germany during 1925-1945. A 60 kW device was built in 1937, and the war bombings ended further research in 1944. A complete 32 page report declassified by the British Intelligence Objectives Sub-Committee is available. (Coler 1946, Nieper 1984) The theories expressed are very similar to those presented in a comprehensive report (GRG 1956) (the latest one we could find so far) on electrogravitics systems, interactions of E-M with gravity, or counterbary control devices.

Toby Grotz and his team are planning to replicate the energy experiments of Walter Russell. In the fall of 1959, General Chapman, Colonel Fry, Major Sargent, Major Cripe, and others from NORAD in Colorado Springs, attended a meeting at Swannanoa, Virginia (University Of Science And Philosophy) at the invitation of Walter Russell. At this meeting Russell explained the workings of a device he proposed to build to take advantage of the vacuum state energy, and the two directional movement of energy from gravitation, (generation), to radiation, (degeneration). During the following year Russell,

his wife, Lao, and their assistants built the device. The prototype that was built consisted of two sets of dual and magnetically-sexed coils. On September 10, 1961, Walter and Lao Russell reported to their contacts at NORAD, that the coils had worked and that the President of the United States could announce to the world that a "greater, safer power than atomic energy" could be provided for industry and transportation.

Don Kelly is the editor of the Space Energy Newsletter (SEA) and has been conducting and reporting results of E-M to gravity drop tests. He finds that energized coil assemblies have a 40% lag in drop time over about five feet. Other related research world-wide verifies that spinning masses appear to lose weight at high rotational speeds.

Stefan Marinov is the editor of Deutsche Physik in Germany and has demonstrated many experiments that confound conventional E-M theory. His recent paper describes devices that create anti-Lenz effects, thus increasing the generator's efficiency.

Stanley Meyer has obtained over 28 patents in both the US and other countries that document his water fuel cell and hydrogen fracturing process technology. He began this work in 1980 and has spent over \$1.6 million. Although he has been approached to sell the technology, he says he has no intention to do so and plans to retain control to make sure his invention is brought to the public for the good of mankind. An informative and recommended videotape of his 1993 ISNE presentation is available through the INE.

John and Kevin Moray are pursuing the technology that was repeatedly demonstrated to the press in the 1930s by T. Henry Moray. One device was reported to generate 50 kW for long periods of time by itself.

Edmund Storms has reviewed much of the work done internationally in the so-called area of 'cold fusion' and has documented the results and repeated results of the now world-wide research in this area.

Floyd Sweet demonstrated his vacuum triode device to at least two expert electronics technicians that have documented their observations in sworn affidavits. A videotape was also made during a demonstration. From a nine volt battery starter unit, nearly continuous output powers of 500 W to 50 kW have been reported to be observed. Experimentation is still in progress to further refine the device and to improve its operational capabilities.

Paramahansa Tewari has been doing experiments with a N-Machine and has reported over-unity

operation from instrument readings. He is currently performing new experiments to feed the output of the device back into the input to obtain a 'free-running' condition. Many researchers have performed experiments with these devices, also called, homopolar generators, or unipolar dynamos. They usually consist of a rotating magnetic disk where electrical current is passed from the center of the disk to its edge. Small increases in the motor input power result in large increases of output power, thus encouraging the idea of an over-unity cross-over point. Regardless of all of the theory and reasons pro and con, it will be exciting to see the results of Tewari's forthcoming experiments and videotapes.

It appears that all serious research and development activities in the energy conversion technologies will continue to be closely monitored and guarded by the existing oil, transportation, and economics industries. Serious researchers in these new areas (Meyer, Methernitha, Sweet) are not allowing "the establishment" to buy them out. At the same time, there is strong evidence of aggressive suppression. The German company Becocraft specializing in the development of "new energy devices" was forcibly shut down and its president quickly imprisoned on investment fraud charges in a court case that had only one plaintiff: the Utility Company of Cologne! (Marinov 1992). All of the investors of Becocraft fought the case to no avail. Closer to home, the US Patent Office has classified over 3,000 patent devices or applications under the secrecy order, Title 35, U.S. Code (1952) Sections 181-188. Where did that technology go? These patents would be a great place to start for a new company involved with defense conversion technologies for environmental use!

## Conclusions

"Woe to you, you blind leaders of a hoard of blind, who say: 'This should be done and that should not be left undone.' You only represent a false teaching and ignore the laws of Creation." <sup>4</sup>

"It has been said that science is man's futile attempt to understand Nature. While it becomes important to learn, understand, and apply science in our everyday lives, it is equally important to continue the pursuit of unraveling the secrets of Nature." (ISNE 1993, from Forward 1).

---

<sup>4</sup> Rashid, Isa; Meier, Eduard. The Talmud of Immanuel, 24:29-30, 1990: Wild Flower Press, PO Box 230893, Tigard, Oregon, 97224, \$17.20.

If ignorance was a good enough reason to not try, the light bulb would have never been invented and the Earth would still be flat. Let us be judged by our work and repeatable results, and not by hasty words. If some of these works turn out to be not valid: So Be It; Let it Be Known; and Let's Move Forward with Integrity! We are all desperately looking for the next big breakthrough in modern physics to assist us in solving the escalating energy and environment crises! Do something to promote and encourage the continuation of these researchers and these works! If you don't do it, who will? If not now, when?

## References<sup>5</sup>

- 26th IECEC, Proceedings of the 26th IECEC, Volume 4, pp 329-492, August 1991: American Nuclear Society, 555 North Kensington Avenue, La Grange Park, IL 60525, \$275.00.
- 27th IECEC, Proceedings of the 27th IECEC, Volume, pp 4.357-4.295, August 1992: Society of Automotive Engineers, 400 Commonwealth Drive, Warrendale, PA 15096-0001, Order No. P-259, \$350.00.
- 28th IECEC, Proceedings of the 28th IECEC, August 1993: American Chemical Society, Meetings Department, 1155 Sixteenth Street N.W., Washington D.C. 20036, \$310.00.
- Adams, R. "The Adams Pulsed Motor Generator Manual," Jan. 1993: Nexus New Times Magazine, PO Box 30, Mapleton Qld 4560, Australia, \$50.00.
- AERI, Advanced Energy Research Institute, 14 Devonshire Mews West, London W1N 1FP, Great Britain.
- AFS, Academy for Future Sciences, PO Box FE, Los Gatos, CA 95031.
- Coler, H., "The Invention of Hans Coler, Relating to an Alleged New Source of Power," British Intelligence Objectives Sub-Committee report No. 1043 Item 31, 32 pp, Now Unclassified, Summer 1946. (Available from the authors for \$5.00)
- Cromer, A., "Pathological Science: An Update," *Skeptical Inquirer*, Vol. 17, pp 400-407, 1993.
- Figgie, H. E. Jr., Bankruptcy 1995: The Coming Collapse of America and How to Stop It, Little, Brown and Company, US and Canada, 1992.
- GRG, Gravity Research Group, "Electrogravitics Systems: An Examination of Electrostatic Motion, Dynamic Counterbary, and Barycentric Control," Feb. 1956: Gravity Research Group report GRG-013/56, Wright Patterson AFB Technical Library, Catalog No. TL 565 A9, WPAFB, Ohio 45433.
- GRI, Group Research Institute, PO Box 438, Nelson, New Zealand.
- IASA, Institute for Advanced Studies at Austin, 4030 Braker Lane W., Suite 300, Austin, TX 78759.
- INE, Institute for New Energy, 1304 South College Avenue, Fort Collins, CO 80524, \$40.00/yr.
- ITS, International Tesla Society, PO Box 5636, Colorado Springs, CO 80931.
- ISNE, Proceedings of the International Symposium on New Energy, April 16-18, 1993: International Association for New Science (IANS), 1304 South College Avenue, Fort Collins, CO 80524, (303) 482-3731, \$45.00. IANS supports the INE.
- JPI, Japan Psychrotronic Institute, c/o Shiuji Inomata, Electrotechnical Laboratory, 1-1-4 Umezono, Tsukuba-shi, Ibaraki 305, Japan.
- Langmuir, I., "Pathological Science," *Physics Today*, 42: 36-48, October 1989.
- Marinov, S., "Regarding Becocraft - Letter to Mr. Richard von Weizsacker, President of the German Federal Republic, 10 October 1992", *Deutsche Physik*, No. 7, East-West Publishers, Morellenfeldgasse 16, A-8010 Graz, Austria.
- Meyer, S. Water Fuel Cell Technical Brief, July 1991: Stanley A. Meyer, 3792 Grove City, OH 43123, \$25.00.
- "New Energy News", PO Box 58639, Salt Lake City, UT 84158-8639: monthly newsletter free to INE members.
- Newman, J., The Energy Machine of Joseph Newman, July 1993: Joseph Westley Newman, Route 1, Box 52, Lucedale, Miss. 39452, \$60.00.
- Nieper, H. A., Revolution in Technology, Medicine and Society, MIT Verlag, Germany, 1984 (In English): Tesla Book Company, PO Box 121873, Chula Vista, CA 91912, \$27.00.
- SEA, Space Energy Association, PO Box 11422, Clearwater, FL 34616.
- Seike, S., The Principles of Ultra Relativity, 11th Ed., 1992: Space Research Institute, Box 33, Uwajima, Ehime (798), Japan, \$70.00.
- Storms, E., "The Status of 'Cold Fusion'," 28th IECEC paper, August 1993.
- TI, Tesla Incorporated, 820 Bridger Circle, Craig, CO 81625.
- USP, Univ. of Science and Philosophy, Swannanoa Place, Box 520, Waynesboro, VA 22980.

## Acknowledgments

The authors gratefully acknowledge these and many other researchers, scientists, and skeptics that have contributed serious open research and documentation to boldly advance science and technology for the benefit of the human race.

<sup>5</sup> Complete addresses and total prices are given.



**UNITED STATES DEPARTMENT OF COMMERCE  
Patent and Trademark Office**

Address: COMMISSIONER OF PATENTS AND TRADEMARKS  
Washington, D.C. 20231

SERIAL NUMBER	FILING DATE	FIRST NAMED APPLICANT	ATTY DOCKET NO
07/460,859	02/13/90	STANLEY A. MEYER	

Porter, Wright, Morris & Arthur  
 Attn: Patricia E. Lanier  
 41 S. High Street  
 Columbus, OH 43215

EXAMINER	
ART UNIT	PAPER NUMBER
	73

DATE MAILED: March 6, 1990

**IF NO RESPONSE TO THIS NOTICE IS RECEIVED WITHIN FORTY-FIVE DAYS, A FORMAL REQUIREMENT WILL BE ISSUED**

The subject matter of this application appears to:

- be "useful in the production or utilization of special nuclear material or atomic energy" as recited in 42 U.S.C. 2182 (Department of Energy (DOE)).
- "have significant utility in the conduct of aeronautical and space activities" as recited in 42 U.S.C. 2457 (National Aeronautics and Space Administration (NASA)).

Accordingly, no patent can issue on this application unless applicant(s) file a statement (under oath or in the form of a declaration as provided by 37 CFR 1.68) setting forth (1) the full facts concerning the circumstances under which the invention was made and conceived and (2) the relationship (if any) of the invention to the performance of any work under any contract or other arrangement with the Agency(ies) noted above. On the reverse side of this form is an example of an acceptable format for this statement. The language appearing in paragraphs III and/or IV of the example *must* appear if applicant is attempting to establish that no relationship (under item 2 above) exists.

If the invention disclosed in this application was developed under a contract, grant or cooperative agreement between the Agency indicated above and a person, small business or non-profit organization and rights to the invention have been determined by specific reference to 35 U.S.C. 202 in the contract, grant or cooperative agreement, then applicant need not submit the statement described above. Instead, applicant may file a verified statement (under oath or in the form of a declaration, 37 CFR 1.68) setting forth the information required by 35 U.S.C. 202(c)(6).

IF NO STATEMENT HAS BEEN RECEIVED WITHIN FORTY-FIVE DAYS OF THE MAIL DATE INDICATED ABOVE, a formal requirement for statement will then be issued. No provision is made for extension of the statutory thirty-day period for response to the formal requirement and the penalty for failure to file an acceptable and timely statement is abandonment of the application. Therefore, applicants are strongly encouraged to submit a statement at this time in order to avoid the issuance of a formal requirement.

IT IS IMPORTANT TO NOTE that the statement must accurately represent the property rights situation of the claimed invention if and when the application is found allowable. Thus, if during prosecution before the examiner, the claimed invention is so altered or the property rights situation so changed as to impact the accuracy of a statement submitted earlier, a supplemental statement must be filed. Failure to submit such additional information where appropriate may be considered a false representation of material facts and render the patent owner vulnerable to loss of patent rights and other sanctions as set forth in the statutes. The PTO will not review allowed applications for this possibility. The responsibility for complying with the statutes rests with the applicants.

Any questions regarding this requirement should be directed to Licensing and Review at (703) 557-3011.

**PLEASE DIRECT ALL COMMUNICATIONS RELATING TO THIS MATTER TO THE ATTENTION OF LICENSING AND REVIEW**

The following is an example of an acceptable property rights statement. Statements of this type are, of course, only suitable for situations in which NO Agency funds or other considerations were involved in the making or conception of the invention. While this example is in the form of a declaration, a sworn document is equally acceptable.

I (We) STANLEY A. MEYER  
citizens of U. S. A.  
residing at 3792 BROADWAY, GROVE CITY, OHIO 43123

declare:

That I (we) made and conceived the invention described and claimed in patent application:

Serial Number 02/460859 filed in the United States of America on 02/13/90  
titled PROCESS APPARATUS FOR PRODUCTION OF FUEL GAS AND THE ENHANCED  
RELEASE OF THERMAL ENERGY FROM SUCH GAS

(Check and complete either I or II below)

(Check III and/or IV below as appropriate)

I. (For Inventors Employed by an Organization) That I (we) made and conceived this invention while employed by \_\_\_\_\_ That the invention is related to the work I am (we are) employed to perform and was made within the scope of my (our) employment duties; That the invention was made during working hours and with the use of facilities, equipment, materials, funds, information and services of \_\_\_\_\_ Other relevant facts are \_\_\_\_\_  
(name of employer)

That to the best of my (our) knowledge and belief:

III. The invention was not made or conceived in the course of, or in connection with, or under the terms of any contract, subcontract or arrangement entered into with or for the benefit of the United States Atomic Energy Commission or its successors: Energy Research and Development Administration or the Department of Energy.

—AND/OR—

That to the best of my (our) knowledge and belief (and/or based upon information provided by \_\_\_\_\_ of \_\_\_\_\_:

IV. The invention was not made (conceived or first actually reduced to practice) under nor is there any relationship of the invention to the performance of any work under any contract of the National Aeronautics and Space Administration.

—OR—

II. (For Self-Employed Inventors) That I (we) made and conceived this invention on my (our) own time using only my (our) own facilities, equipment, materials, funds, information and services. Other relevant facts are NOVE

The undersigned inventor(s) declare further that all statements made herein of his or her (their) own knowledge are true and that all statements made on information and belief are believed to be true and further that these statements are made with the knowledge that willful false statements and the like so made are punishable by fine or imprisonment, or both, under Section 1001 of Title 18 of the United States Code and that such willful false statements may jeopardize the validity of the application or any patent issuing thereon.

Inventor's Signature: Stanley Meyer

Post Office Address: 3792 BROADWAY, GROVE CITY, OHIO 43123

Date: 03/13/90

Inventor's Signature: N/A.

Post Office Address: N/A

Date: N/A.

**WATER FUEL CELL**  
Document of Records

**Electrical Polarization Process  
Voltage Intensifier Circuit (VIC)**

Copy of Document

Certificate of Registration  
Patent Cooperation Treaty (PCT) Act  
U.S. Patent Validation Report  
Natural Water Hydrogen Generation System  
U.S. Patent Application: S/N 6/302,807 filed Sept. 16, 1981

The U.S. Government has allowed the WFC Technology of Inventions to go forward into the International Market Place by issuing foreign grant license No. 492680 issued July 10, 1989 and foreign grant license No. 490606 issued Nov. 15, 1989 to Stanley A. Meyer as so specified under U.S. Presidential Executive Order (MPEP 708,02VI ENERGY) in compliance with The Patent Cooperation Treaty (PCT) Act as so mandated under the U.S. War Powers Act. Heavy fines and imprisonment are levied on anyone who falsely claims to have participated in the development of a invention. Under the PCT Treaty Act, a Declaration of Oath must be signed, certified, and registered prior to the filing of any PCT patent application. Notice of "Executive Order To Protect" is hereby invoked immediately under the War Power Act, as confirm and attested by Inventor, Stanley A. Meyer, as "Record of Filing" contained herein, as said "Posting of Records" being presented as Public "Record of Review."

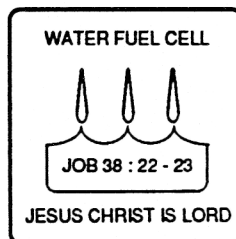



## Electrical Polarization Process

### Amp Inhibiting Circuit

#### WFC U.S. Patent Validation Report

U.S. Patent Application: S/N 6/302,807 Filed Sept. 16, 1981

#### Natural Water Hydrogen Generation System

As in reference to attached WFC Patent Validation Report dated January 14, 1983 as per WFC Test-Results "Mode of Operability" of using "Voltage Potential" to dissociate the water molecule (without chemical additives) (called WFC Electrical Polarization Process hereinafter) as so specified under U.S. Patent Office (35 USC 101) to demonstrate operability, the applied Pulse-Voltage Frequency is adjusted to tune-in to the dielectric properties of water by the use of WFC "Amp Inhibiting Circuit" (Figure 8XA) titled WFC "Voltage Intensifier Circuit" (VIC), as further illustrated in WFC Tech-Brief titled "The Birth of New Technology"... WFC U.S. Patent Memos 420 ~ 428, including "Table of Tabulation" (Appendix A) as to "Glossary of Application Notes" (Appendix B):

The Amp Inhibiting Circuit (Figure 8XA) is composed of two copper wires "Bifilar" wound (Wrapped) about a magnetic induction core to allow amp restriction (Minimizing Current Leakage) while encouraging "Voltage Potential" across the water molecule to perform WFC "Electrical Polarization Process", as so illustrated in Figure (7-1) WFC Memo 426 titled VIC Matrix Circuit. The Hi Pulse-Voltage energized "Resonant Charging Choke (56) of Figure (7-1) as to Figure (8XA) creates an electromagnetic coupling field (Rp1) of Figure (7-8) that crosses over and passes through electrically ground connected Resonant Charging Choke (62), as to Figure (8XA1) ... causing amp flow restriction during each Pulsing-Cycle since electrons exhibit electromagnetic characteristic. The resultant Amp Inhibiting Circuit (Figure 8XA) as to (Figure 8XA1) further allows amp restriction (minimizing current leakage) to be continued even if applied "Voltage Amplitude" is increased. The length and diameter size of the copper-wire spiral wrapped coils (56/62) of Figure (8XA) being paired together and electrically energized in conjunction with applied Voltage Pulse-Frequency determines how much "Amp Leakage" will occur while "Pulse-Voltage Potential" dissociates and separates the water molecule by way of "Opposite Electrical Attraction Force" into water gases of hydrogen, oxygen, and ambient air gases, as so confirmed by Analytical Research Associates, Inc. testing-report herein attached. Connecting Amp Inhibiting

Circuit (8XA) to an external Pulsing "Voltage Source" such as a "Step-Up" transformer, now, forms the "Voltage Intensifier Circuit" (VIC) (Figure 8XA1), as so illustrated in VIC impedance network schematic (Figure 7-1) as to VIC Matrix Circuit (7-8). Other amp restricting circuits are, also, applicable such as applying a variable (0-5) volts unipolar pulse-frequency across the armature field-winding of a de-regulated alternator functioning as a pulse-voltage frequency generator, as so illustrated in Photo Exhibits 11B, 11B1, and 11C. The electronic circuit design interfacing determines the amount of "amp leakage" that may occur during WFC "Electrical Polarization Process".

The "Mode of Operability" of the WFC "Electrical Polarization Process" as so established herein by way of said WFC Test-Report is/was determined by the "Preset" Conditions as so specified by the U.S. Patent Office (35 USC 101) under preselected testing procedures performed by Robert L. Ward (see Robert L. Ward" affidavit relating to technical characteristics of non-chemical "Natural Water Hydrogen Gas Generation System" (hereinafter called Water Fuel Cell): various natural water samples analyzed by spectrophotometer method by R & D Laboratory, 2331 Sullivant Ave., Columbus, Ohio 43204, tel. 1-614-274-6467; Analysis of the released water-gases by gas Chromatographic method by Analytical Research Associates, Inc., 3274 Maize Road, Columbus, Ohio 43224, Tel. 1-614-267-0279; Analysis by MC Material Joining Consultant of the " technical Characteristics" of Stainless Steel (T304) material (chemically inert to the Electrical Polarization Process) forming the voltage-zones (hereinafter called Excitor Plates) when immersed in natural water undergoing the "Electrical Polarization Process" ... as so witnessed by Stanley Graumlich and Charles C. Holbrook "Affidavit of Witnessed" as to how said WFC Patent Validation "Test-Report" had been conducted as per WFC "Record of Filing" with the U.S. Patent Office ... demonstrating the dissociation of the water molecule by way of "Voltage Potential" before the U.S. Patent Office Scientific Review-Board of Inquiry (January 11, 1984) as so established by said "Certificate of Registration" of said attached WFC U.S. Patent Validation Test-report , as herein presented.

In terms of "Preset" conditions pertaining to the "electrolysis" process of the prior art, chemical additives (electrolyte) such as Sodium hydroxides or Potassium hydroxides must be added to distilled water (typically, 20% per liquid volume) to attempt to maximize hydrogen gas production, as herein the added electrolyte creates a "Dead Short" condition not allowing "Voltage Potential" to exceed two (2) volts potential while linear amp flow proportionally determines hydrogen gas production (see comparison graph titled WFC "Mode of Operability" as herein attached), as herein said electrolysis process decomposes both the bi-metals electrodes and the added "electrolyte" simultaneously during said hydrogen gas production, as herein said

electrolysis gas-yield nets about one (1) cubic centimeter (CC) per one (1) amp/hr. @ 2 Volts potential ... wherein, said electrolysis process solely relying on the use of very high amp flow ... consuming electrical power in the form of heat energy. Contaminates in distilled water and/or said chemically additive (electrolyte) causes "Electrode Filing" (forming a oxidizing coating) which terminates the "electrolysis" prematurely.

Whereas, WFC Electrical Polarization Process (EPP) overcomes the self-destructing effect (Operational Parameters)(Preset Conditions) associated with the prior art "electrolysis" process; while, hydrogen gas-yield related to the "Electrical Polarization Process" far exceeds the prior art "electrolysis" process (see WFC Differential Efficiency Factor) ... utilizing chemically inert Stainless Steel (T304) material (decomposition rate .0001/yr) forming opposite "Voltage Zones" (E1/E2)(MC Material Joining Consultant Report) being immersed in natural water (R & D Laboratory Report) ... releasing only hydrogen, oxygen, and ambient air gases from said natural water, as so illustrated in gas-sample report by Analytical Research Associates.

Beyond amp restricting characteristic of said Amp Inhibiting Circuit, the spiral-wrapped coils being paired together (See Figure 8XA, once again), also , causes voltage level enhancement beyond applied voltage input since the "Distributed Capacitance" ( $C1a \times \times \times C1n \approx C2a \times \times \times C2n$ ) / "Distributed Inductance" ( $FL1a \times \times \times FL1n \approx FL2a \times \times \times FL2n$ ) of said "bifilar" wrapped coils (Figure 7-3) as to VIC Diagram (AA) encourages the compounding effect (increasing magnetic field-strength during each pulsing cycle) of electromagnetic field-strength ( $Rp1a \times \times \times Rp1n \approx Rp2a \times \times \times Rp2n$ ) (mutual induction) when applied Pulse-voltage Frequency (49a  $\times \times \times$  49n) of Figure (3-34) passes through the positive energized Resonant Charging Choke (56). Furthermore, the paired coils-wires opposite voltage potentials [positive electrical attraction force (B+)  $\approx$  negative electrical attraction force (B-)] [hereinafter called Electrical Stress (SS'  $\approx$  RR')] as to (160) of Figure (3-26)] are always equal in electrical magnitude/intensity since the wire-length of each coil are the same. Pulse-voltage repetition rate sets up the step-up electrical charging effect (Figure 1-3) since the "Resonant Cavity" functions as a "Capacitor" (ER) due to the dielectric value of water which becomes an integral part of the VIC Circuit, as so illustrated in (650) of Figure (7-4). The resultant voltage enhancement (Voltage Amplitude) can exceed 40 kilovolts to instantly convert water (droplets) into thermal explosive energy (gtnt), as so illustrated in Voltage Intensifier Circuit Diagram (AA).

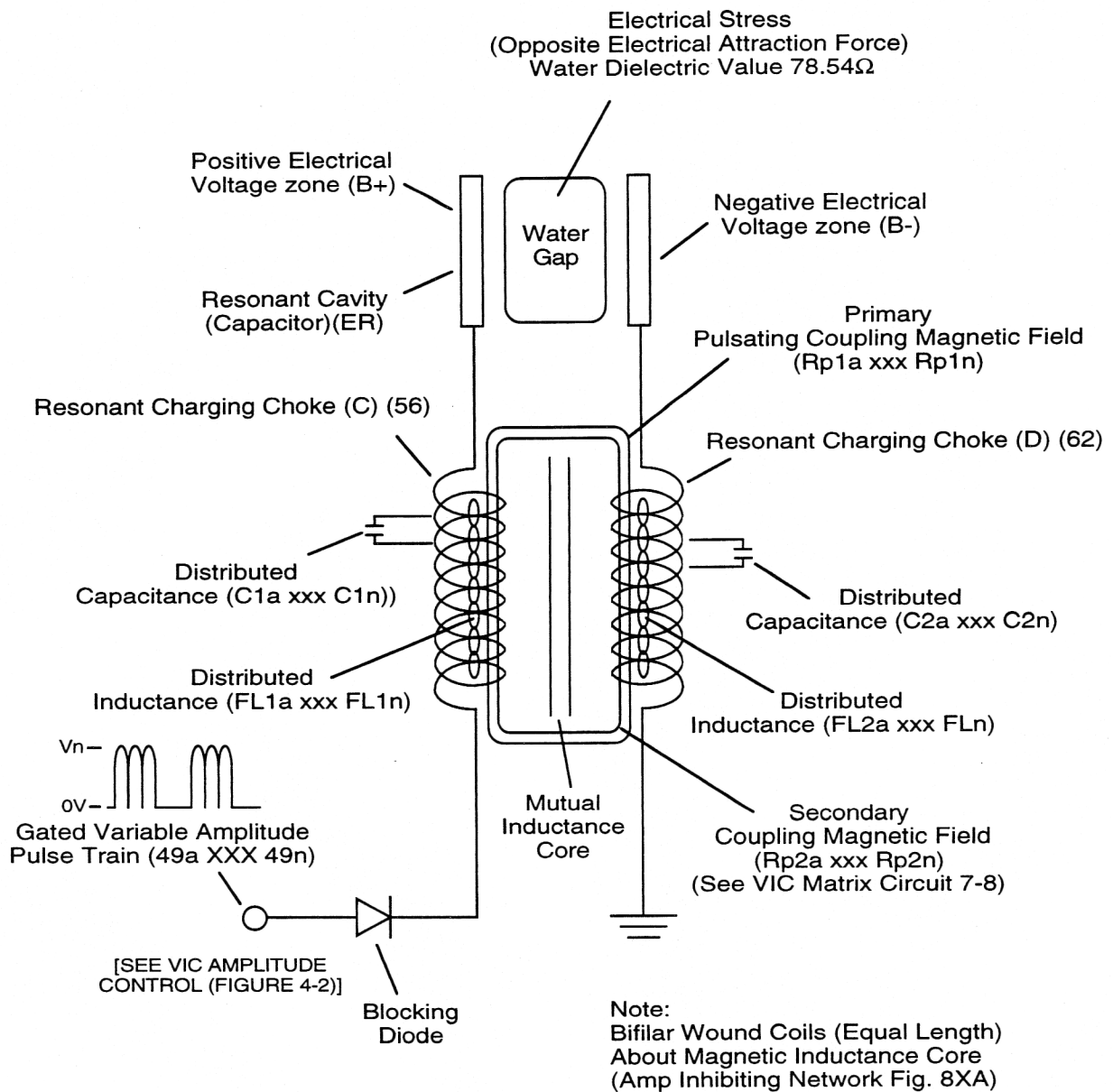
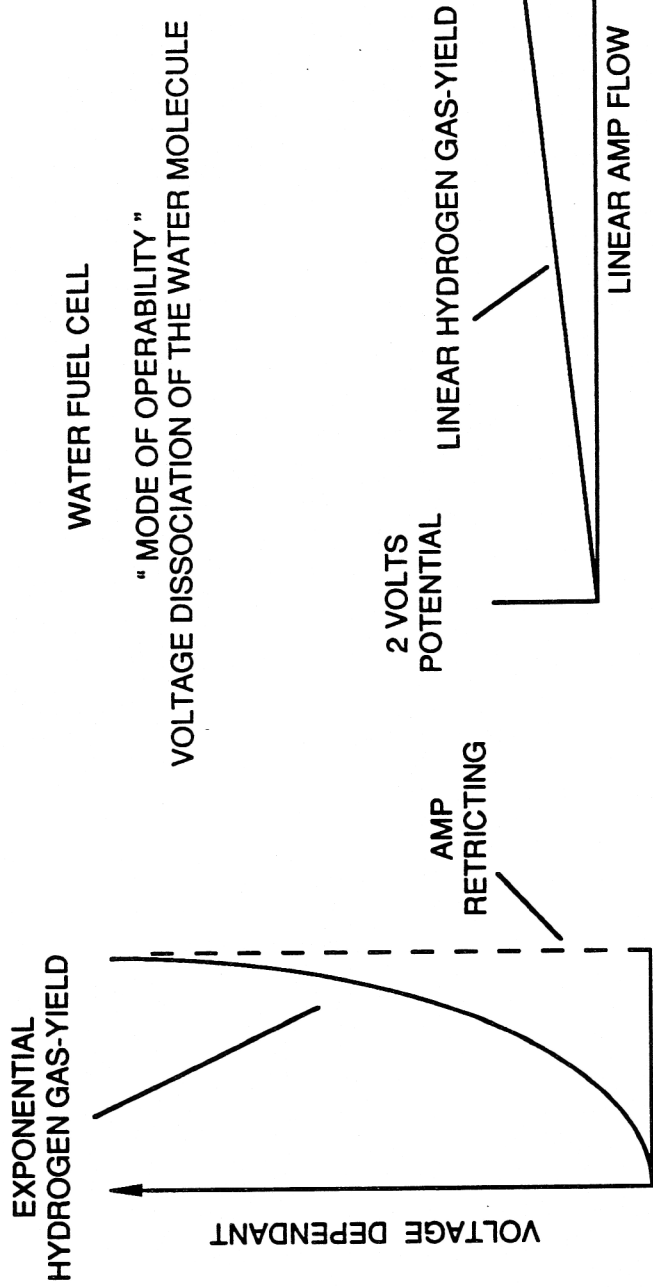

FIGURE AA: VOLTAGE INTENSIFIER CIRCUIT DIAGRAM



WFC ELECTRICAL POLARIZATION PROCESS  
(ELECTRICAL ATTRACTION FORCE OF OPPOSITE POLARITY)  
REQUIRES NATURAL WATER ONLY

PRIOR ART ELECTROLYSIS PROCESS  
(CHEMICAL INTERACTION CURRENT DEPENDANT)  
REQUIRES ELECTROLYTE ... DEAD SHORT CONDITION

### Electrical Polarization Process Vs Prior-Art Electrolysis Process

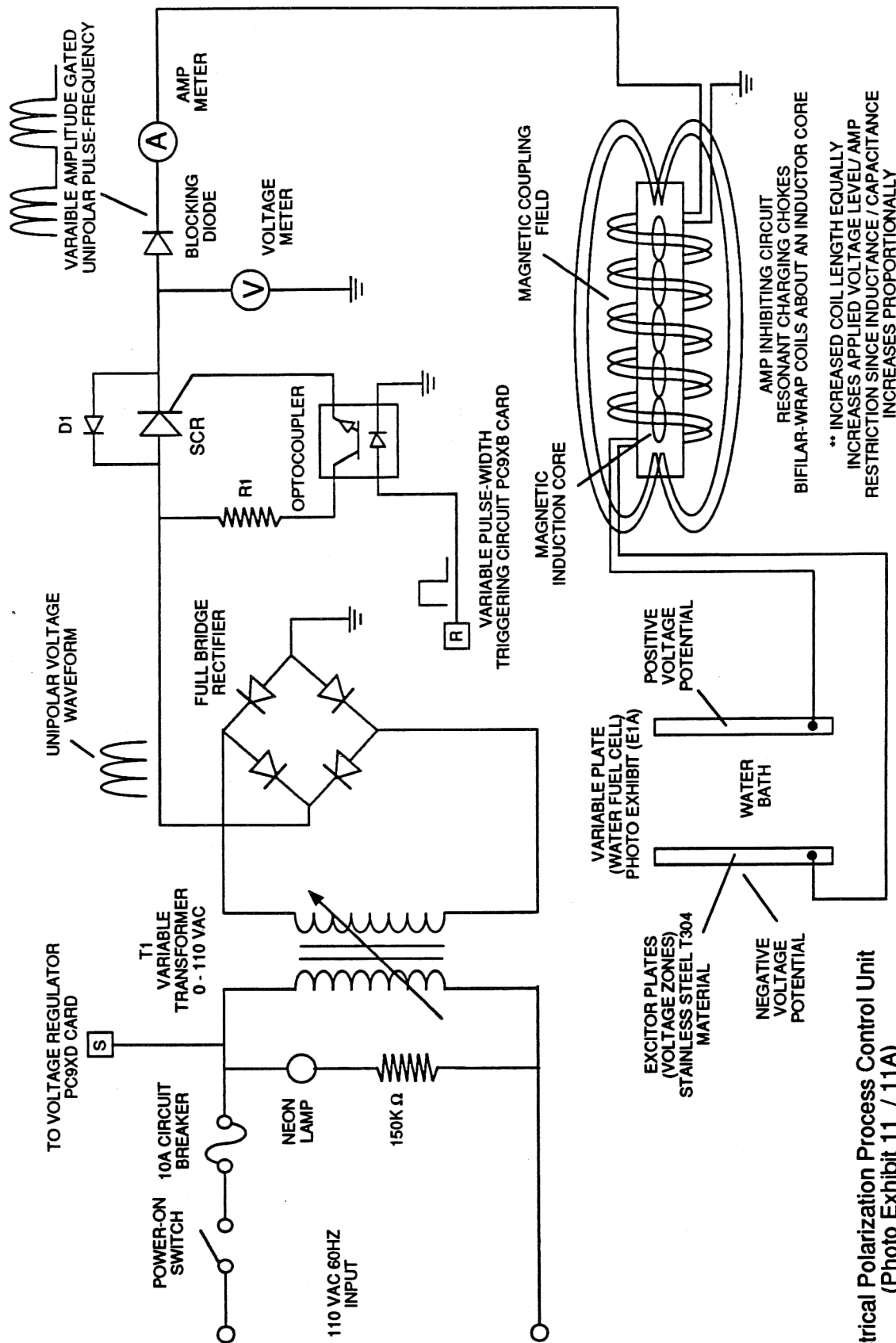

Electrical Polarization Process Control Unit  
(Photo Exhibit 11 / 11A)

FIGURE 8XA: VOLTAGE INTENSIFIER CIRCUIT (VIC)

Copyright © 1981 By Stanley A. Meyer

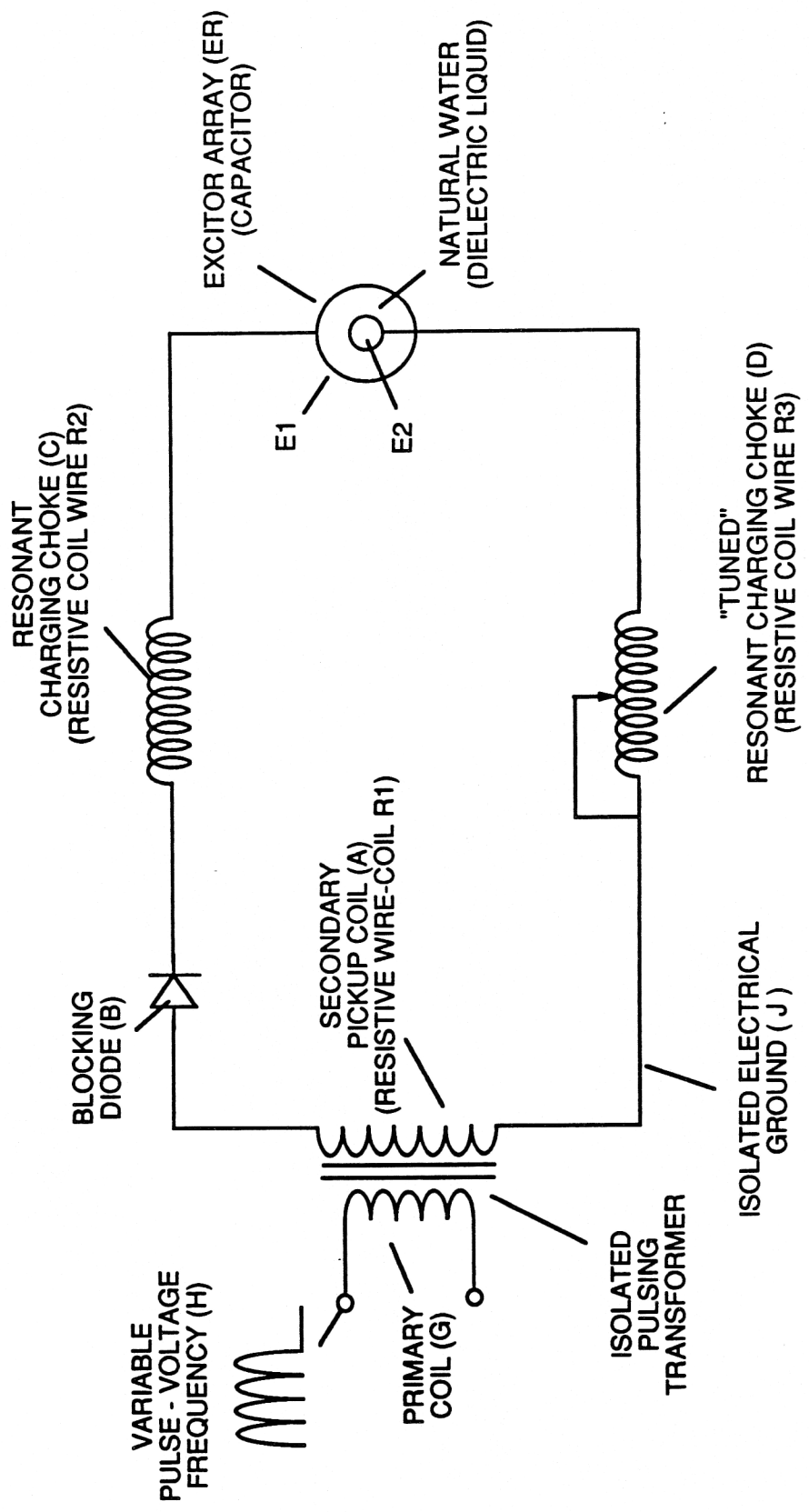
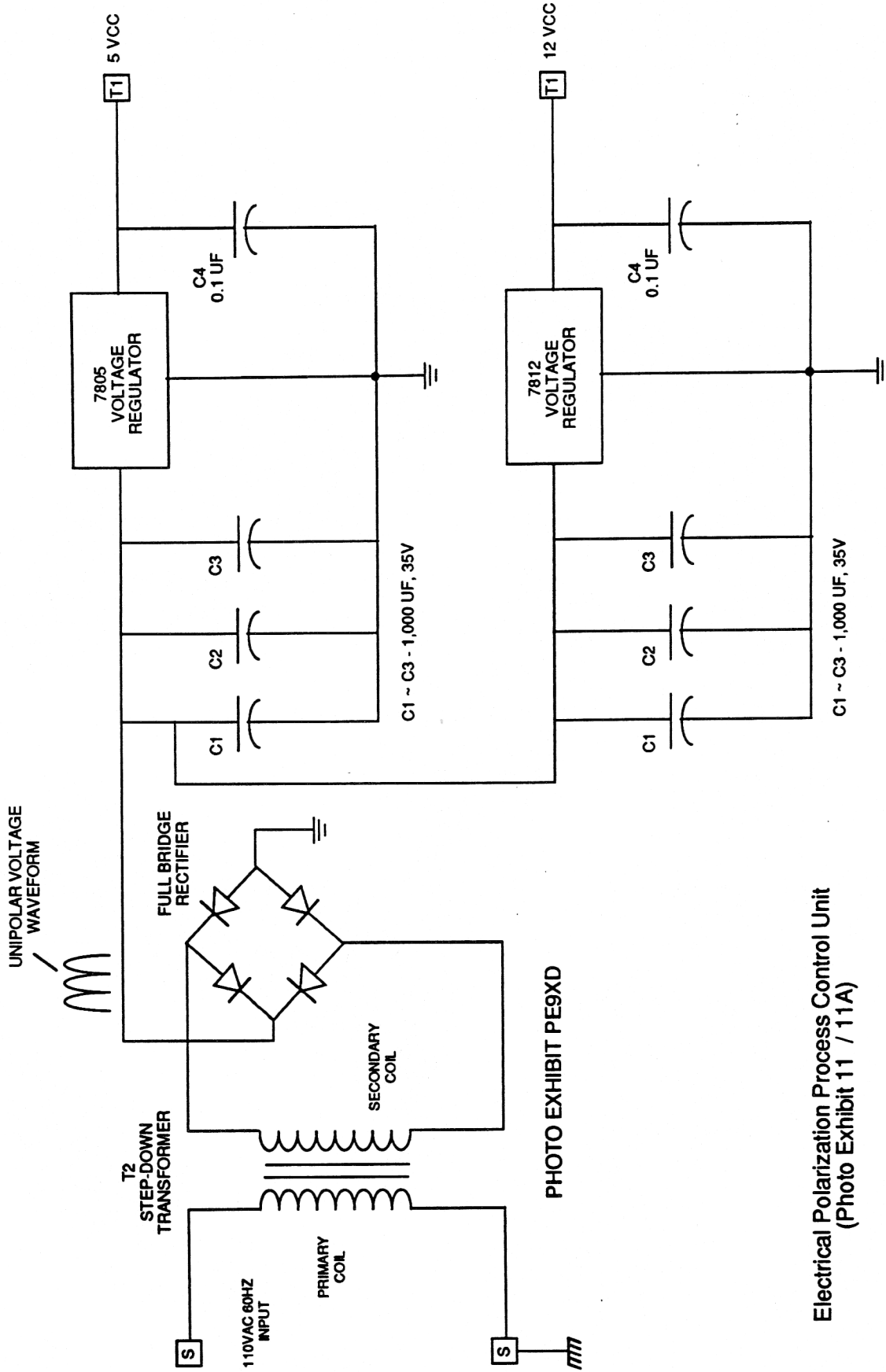

FIGURE 8XA1: Voltage Intensifier Circuit (AA)

Copyright © 1981 By Stanley A. Meyer



Electrical Polarization Process Control Unit  
(Photo Exhibit 11 / 11A)

FIGURE 9XD: VOLTAGE REGULATOR PC9XD CARD SCHEMATIC

Copyright © 1981 By Stanley A. Meyer



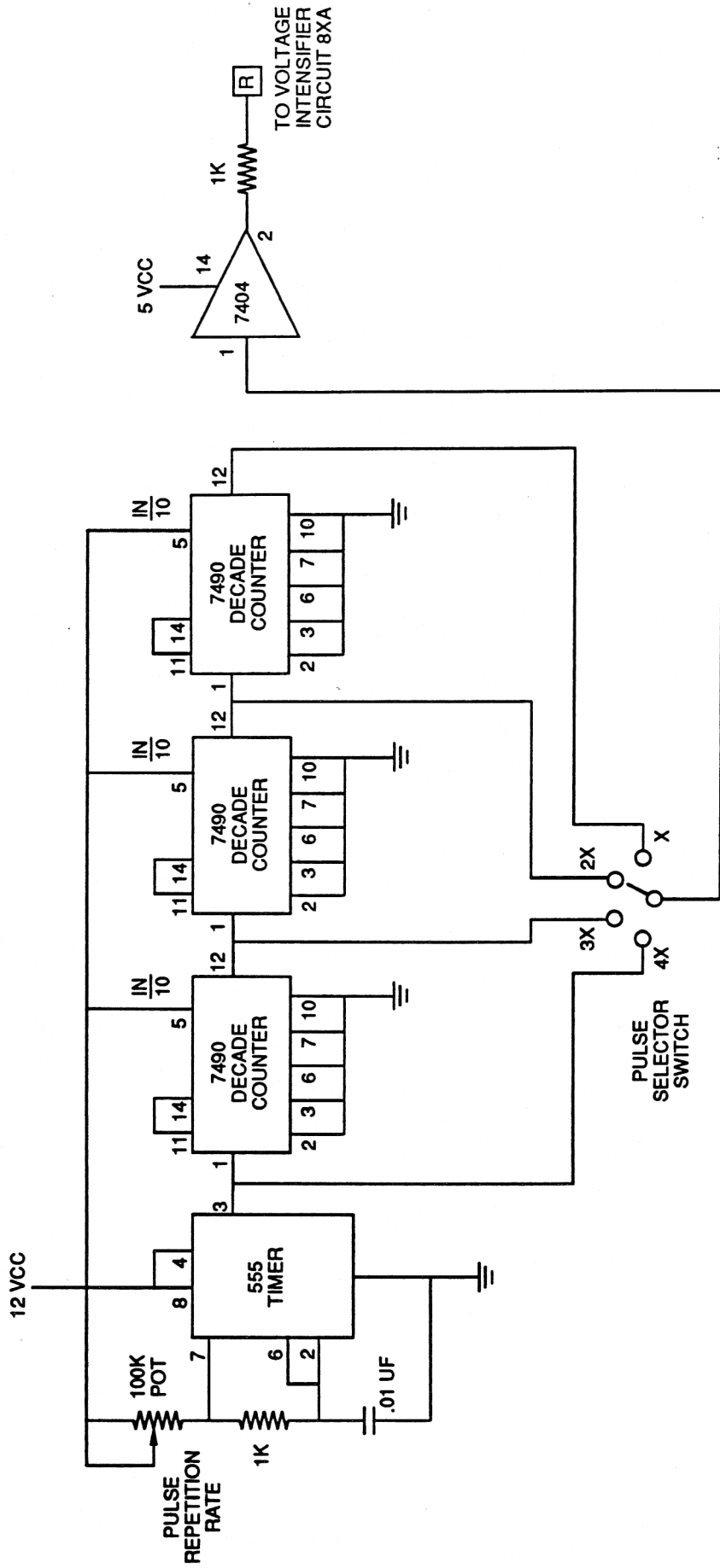

PHOTO EXHIBIT PE9XB

Electrical Polarization Process Control Unit  
(Photo Exhibit 11 / 11A)

FIGURE 9XB: VARIABLE PULSE GENERATOR SCHEMATIC

Copyright © 1981 By Stanley A. Meyer



# WATER FUEL CELL (Demonstration Unit)

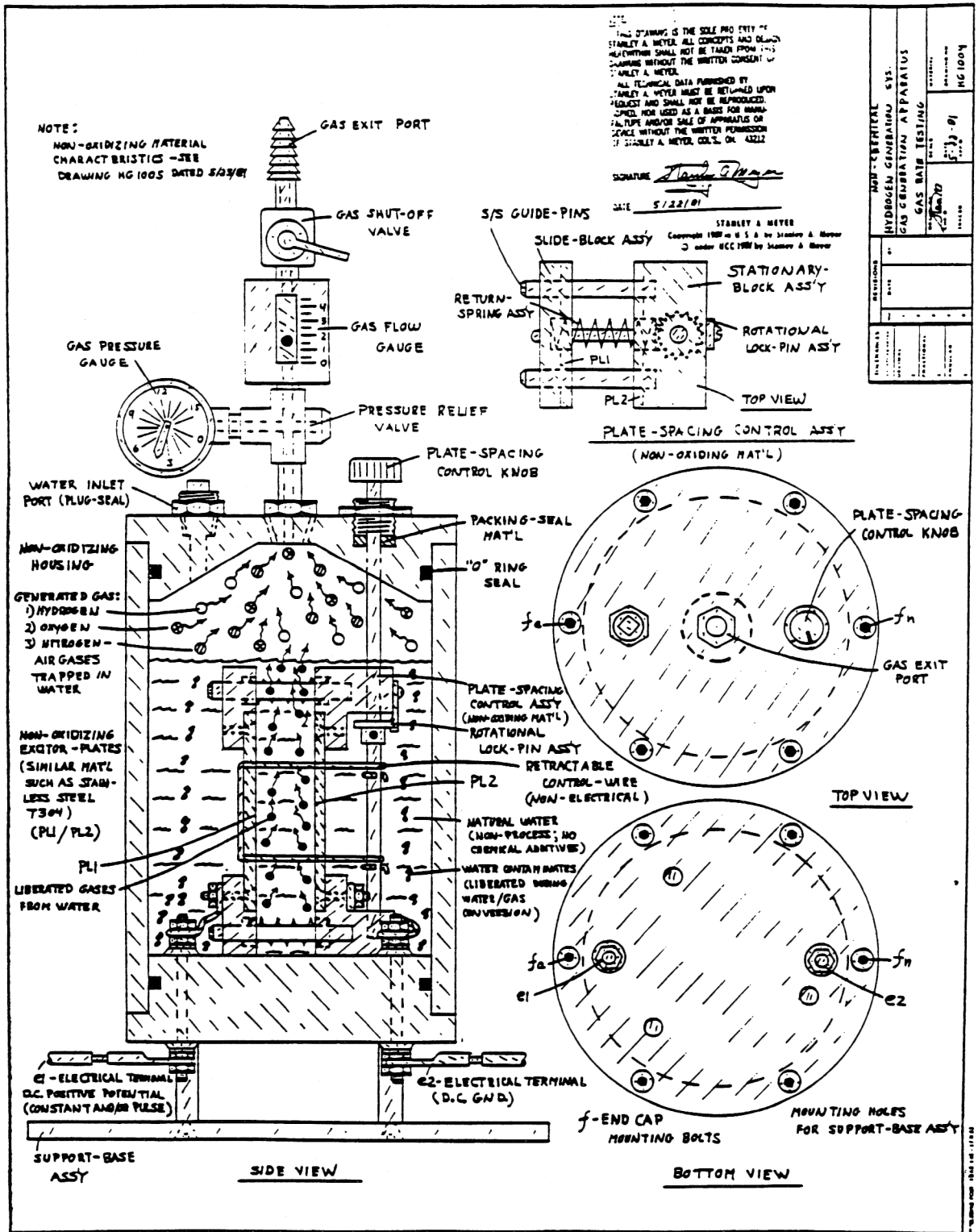

## EXHIBIT E1: VARIABLE SPACING

# WATER FUEL CELL (Demonstration Unit)

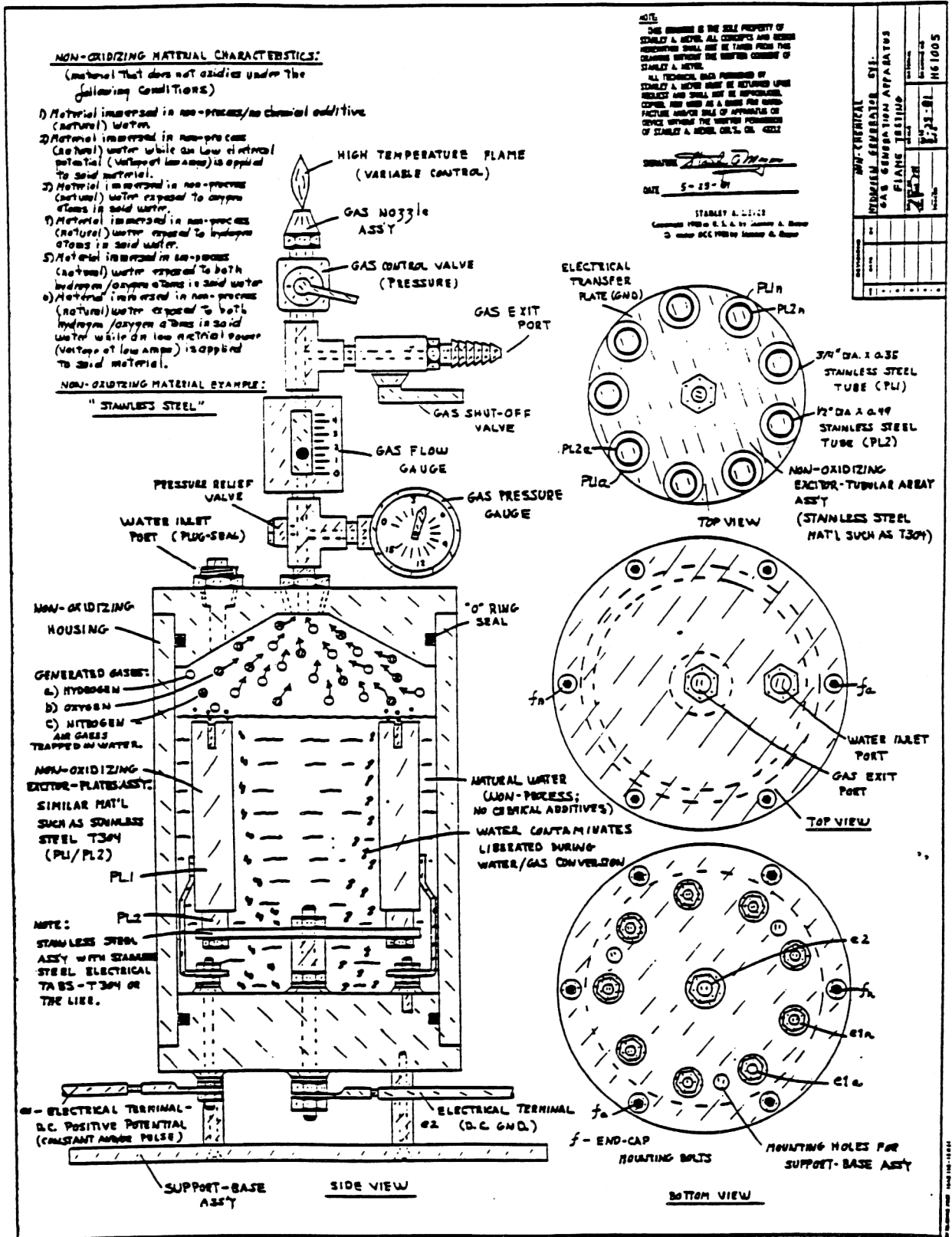

## EXHIBIT E2: TUBULAR CLUSTER-ARRAY

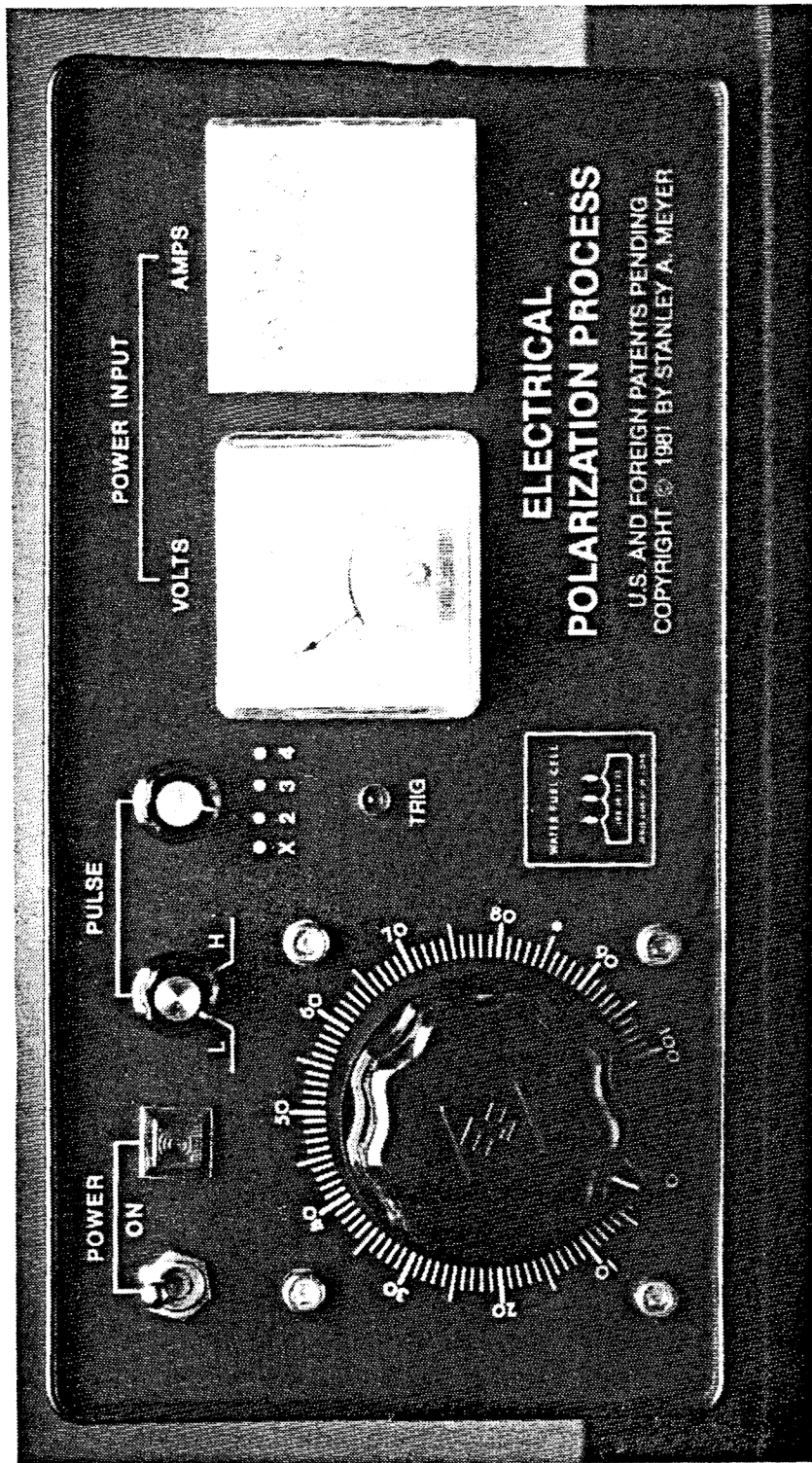

**PHOTO EXHIBIT 11: INTEGRATED GAS-RATE CONTROL UNIT**

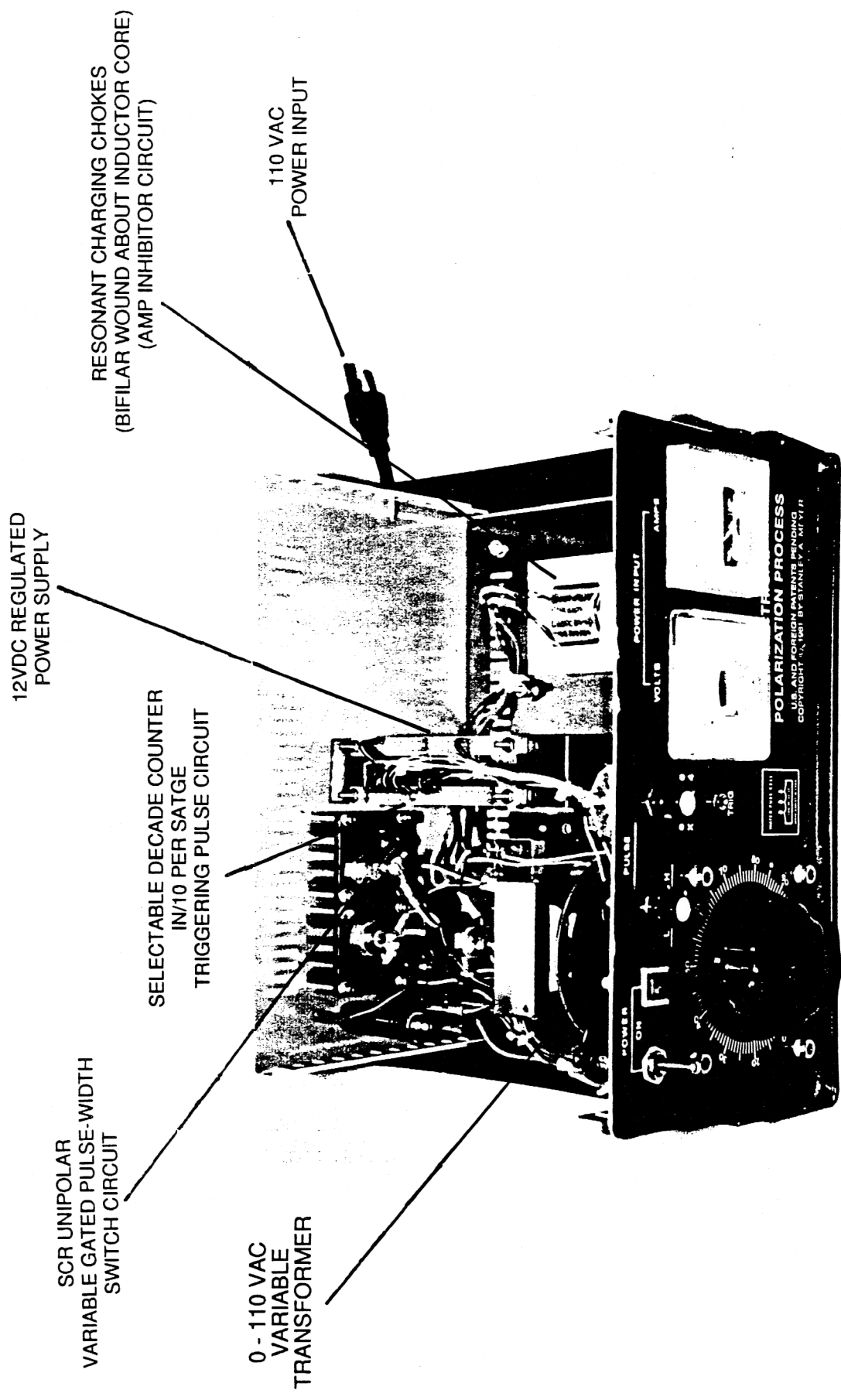
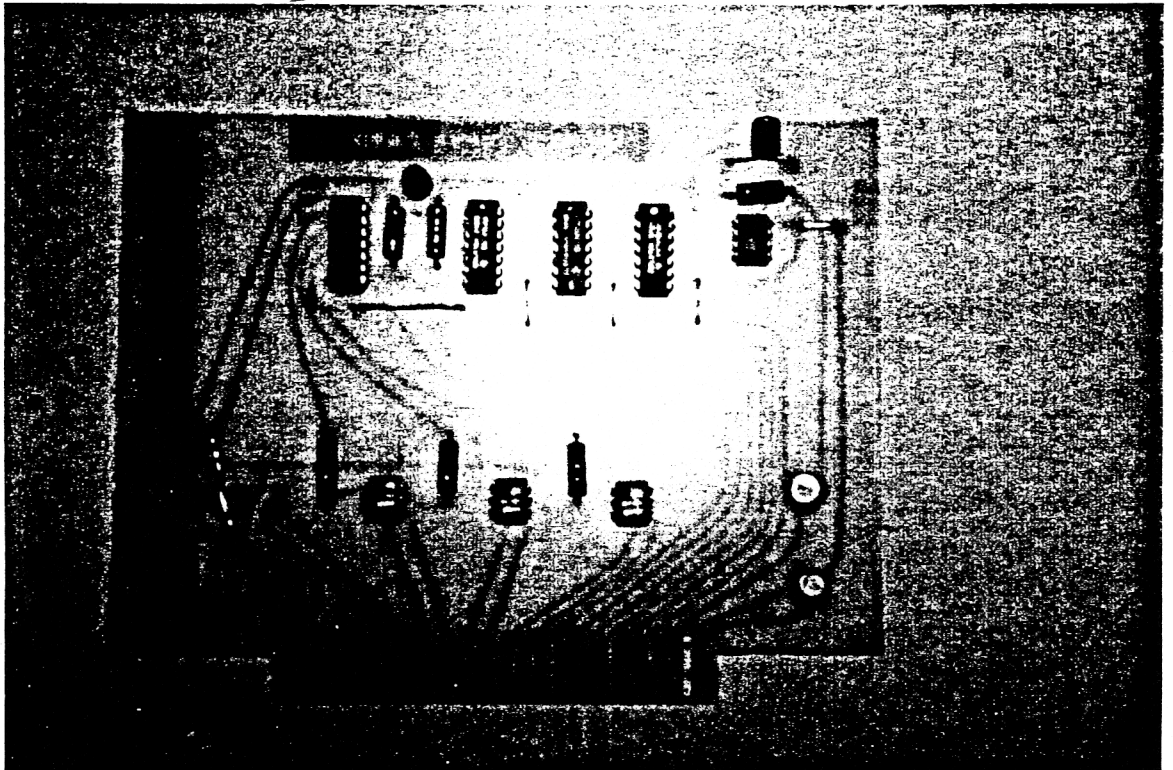

PHOTO EXHIBIT 11A: ELECTRICAL POLARIZATION PROCESS  
 RESONANT CHARGING CHOKE CIRCUIT (Fig. 9XA)

Copyright © 1981 by Stanley A. Meyer

# Electrical Polarization Process



Variable Pulse Triggering Circuit (Component View)

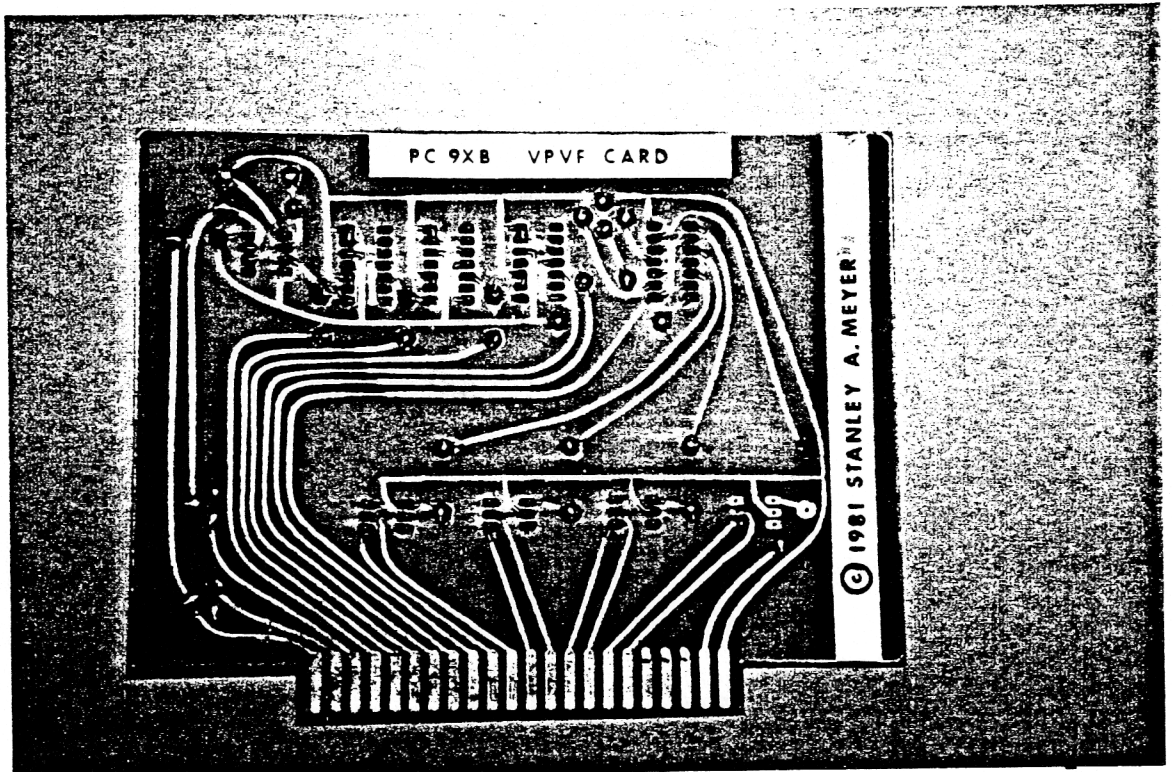

Variable Pulse Triggering Circuit (Foil Side)

Electrical Polarization Process

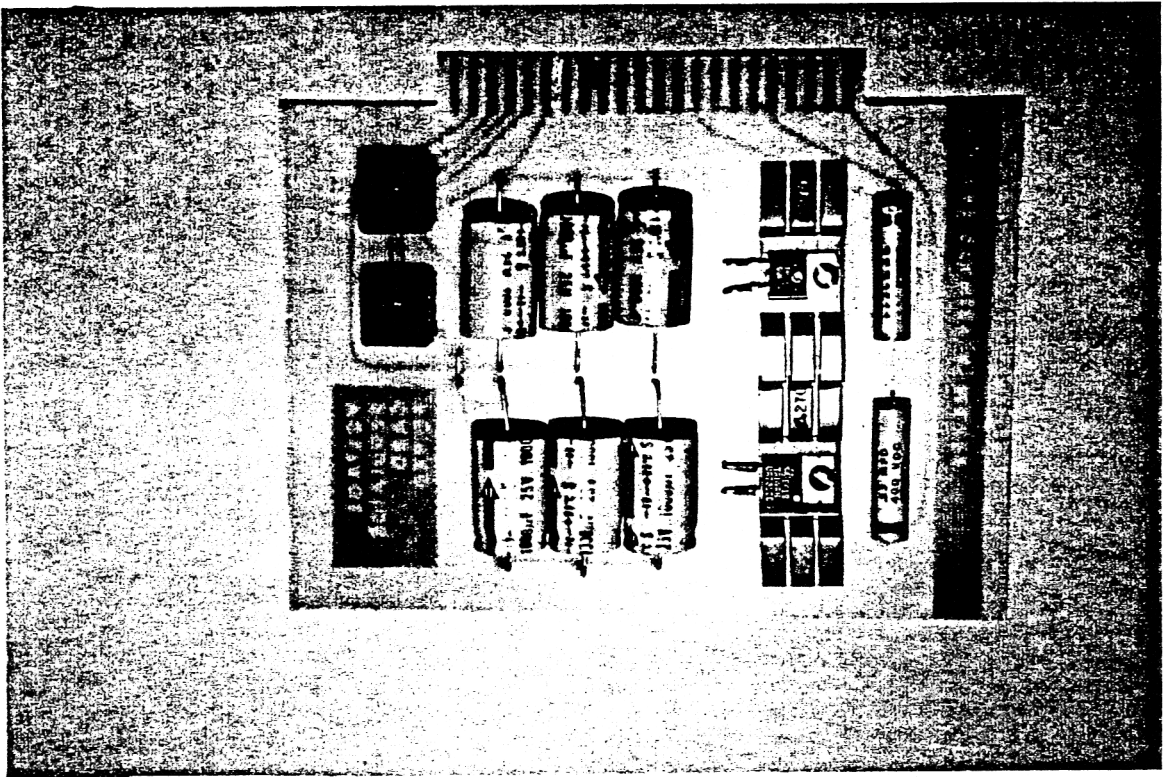

Voltage Regulator Card PC 9XD (Component View)

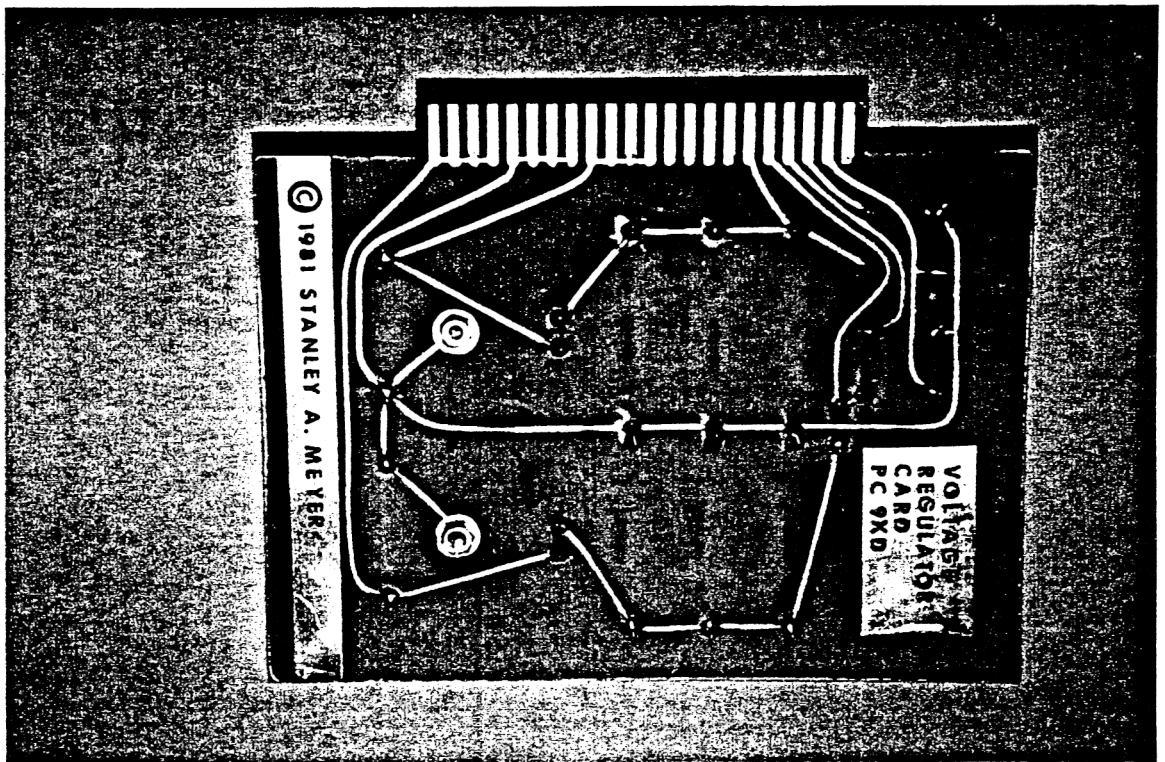

Voltage Regulator Card PC 9XD (Foil Side)



EXHIBIT PHOTO E1A:

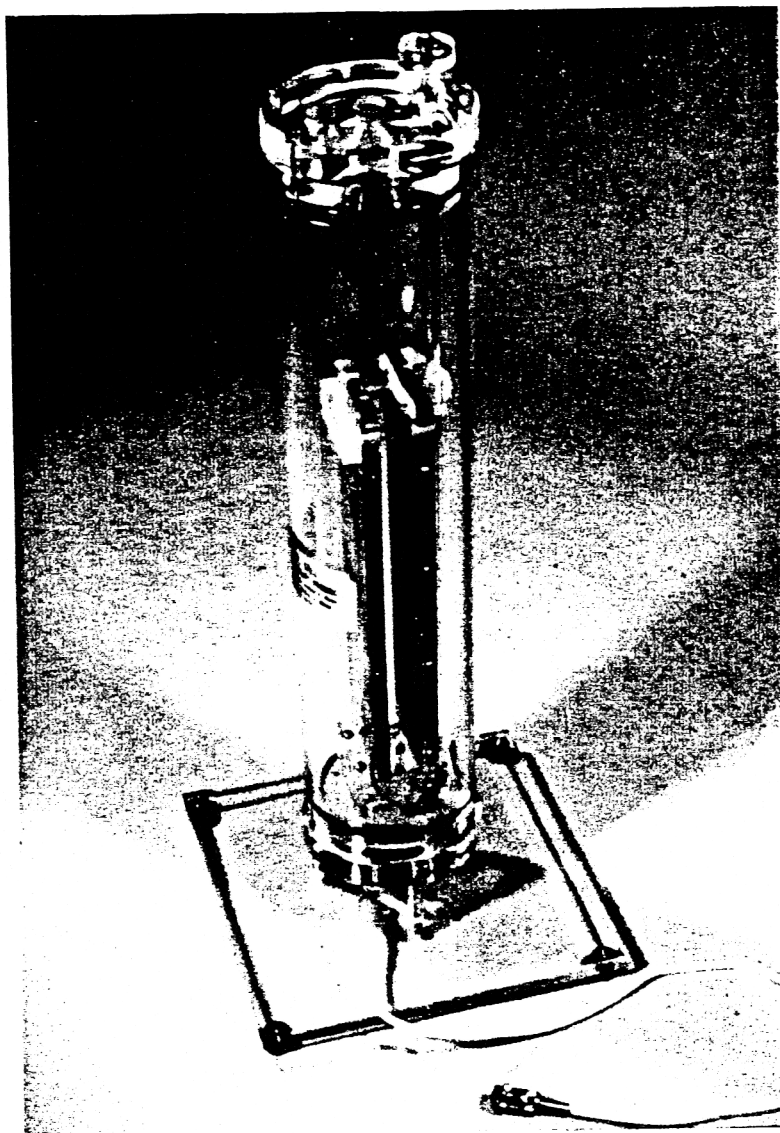

VARIABLE PLATE SPACING TEST UNIT

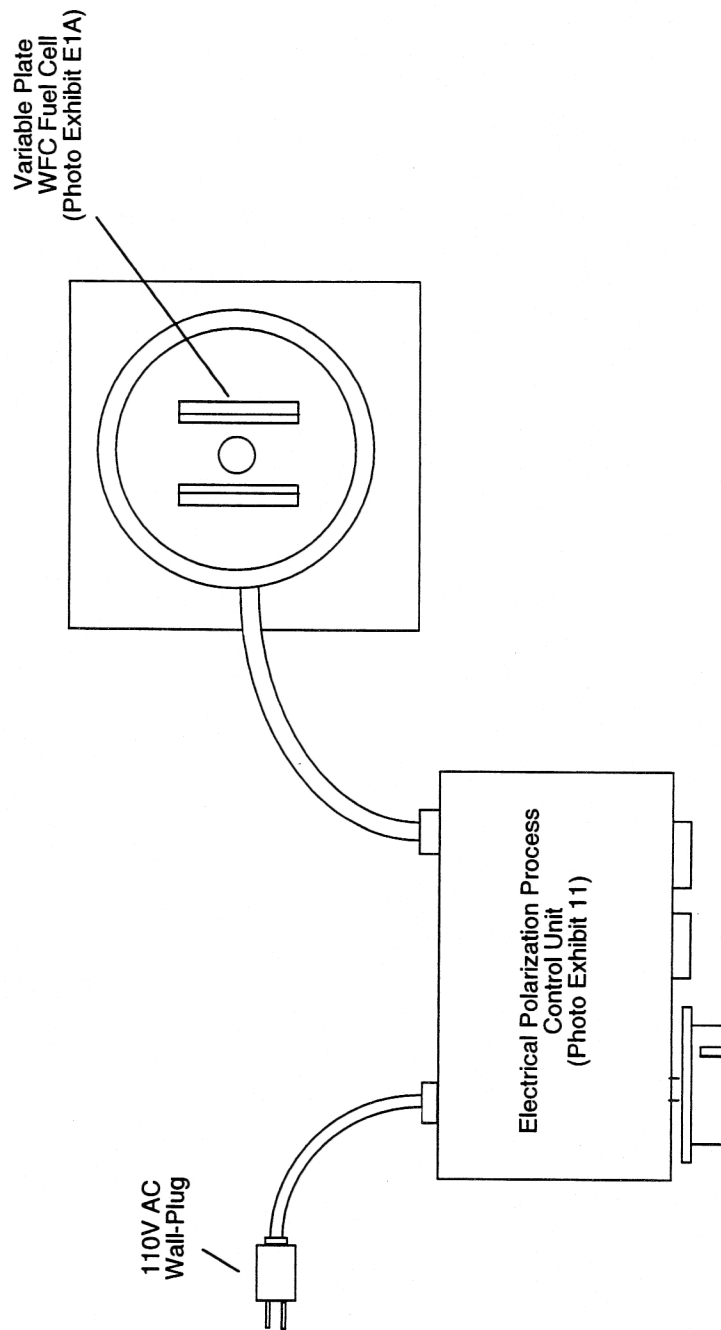

**Figure 11E: Variable-Plate WFC Fuel Cell  
Electrical Hookup (Top View)**

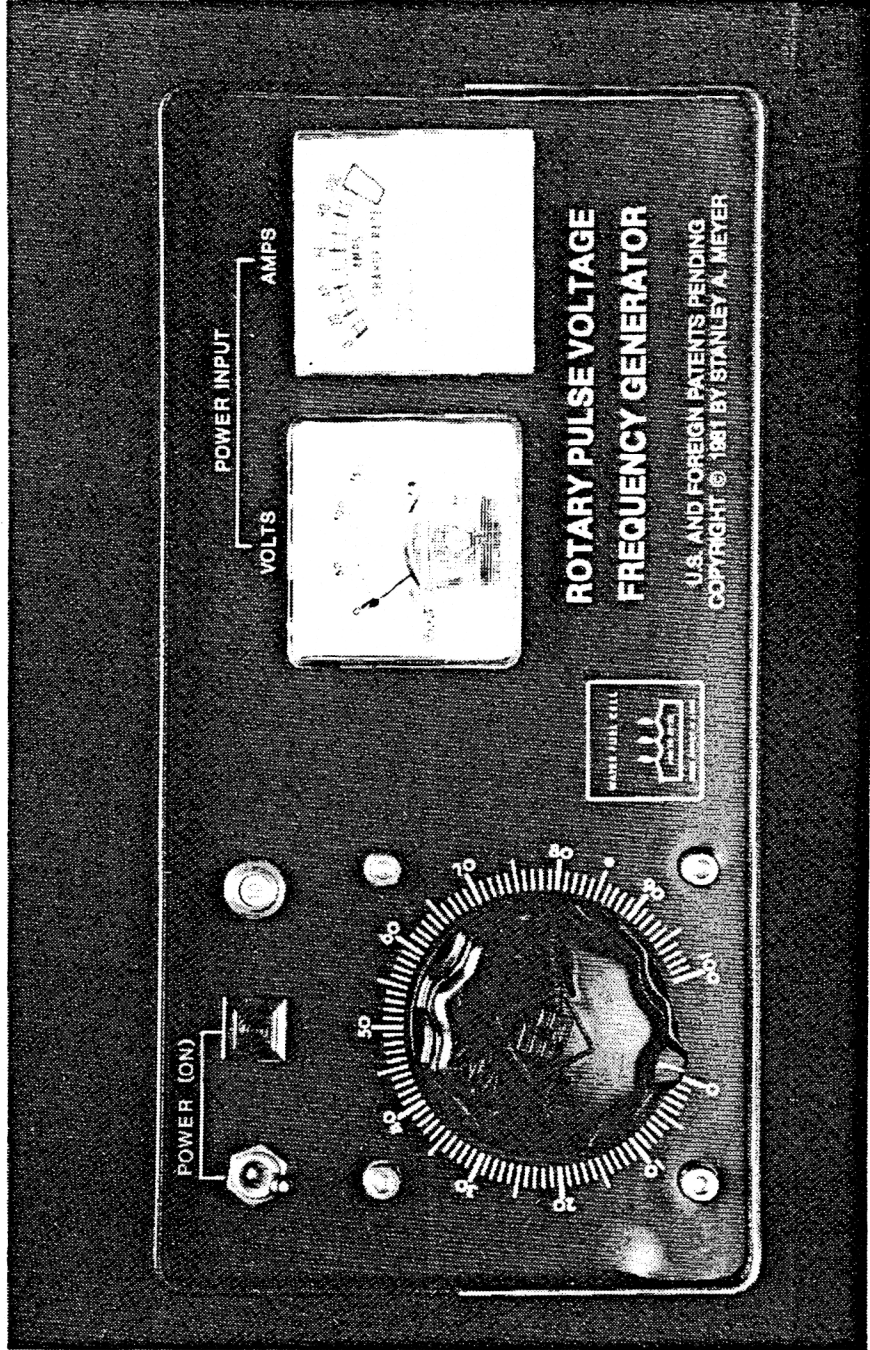

**PHOTO EXHIBIT 11B: ROTARY PULSE VOLTAGE  
FREQUENCY CONTROL UNIT**

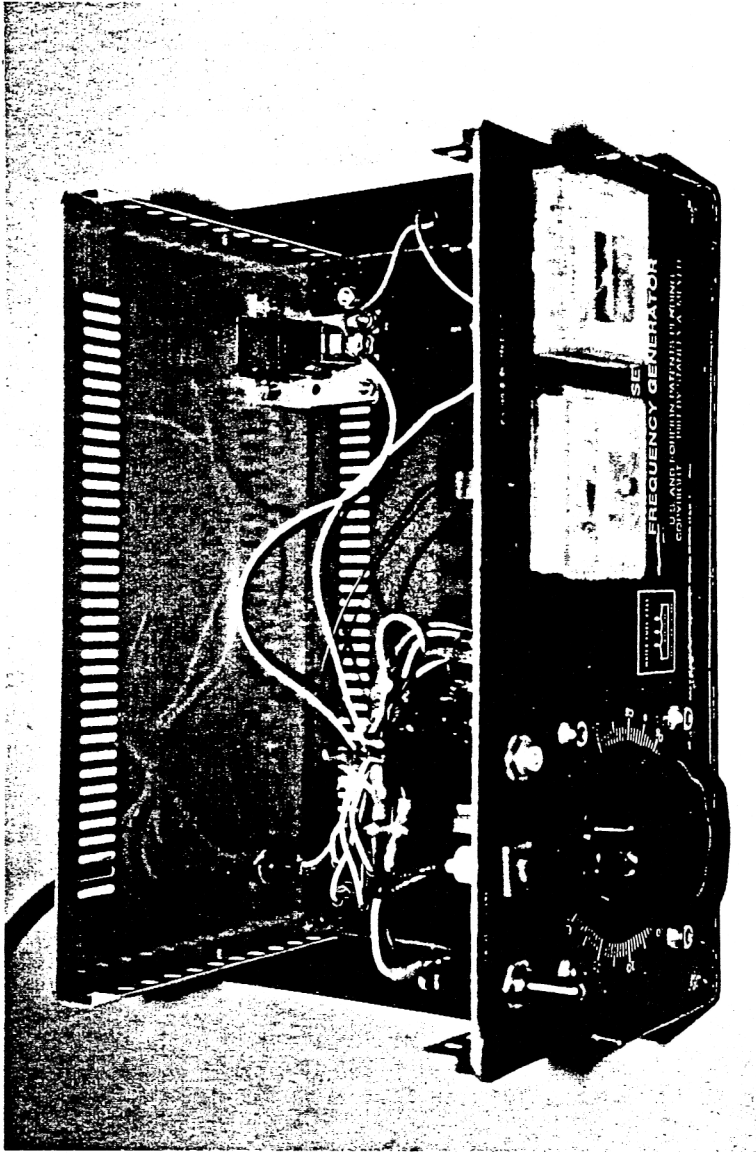
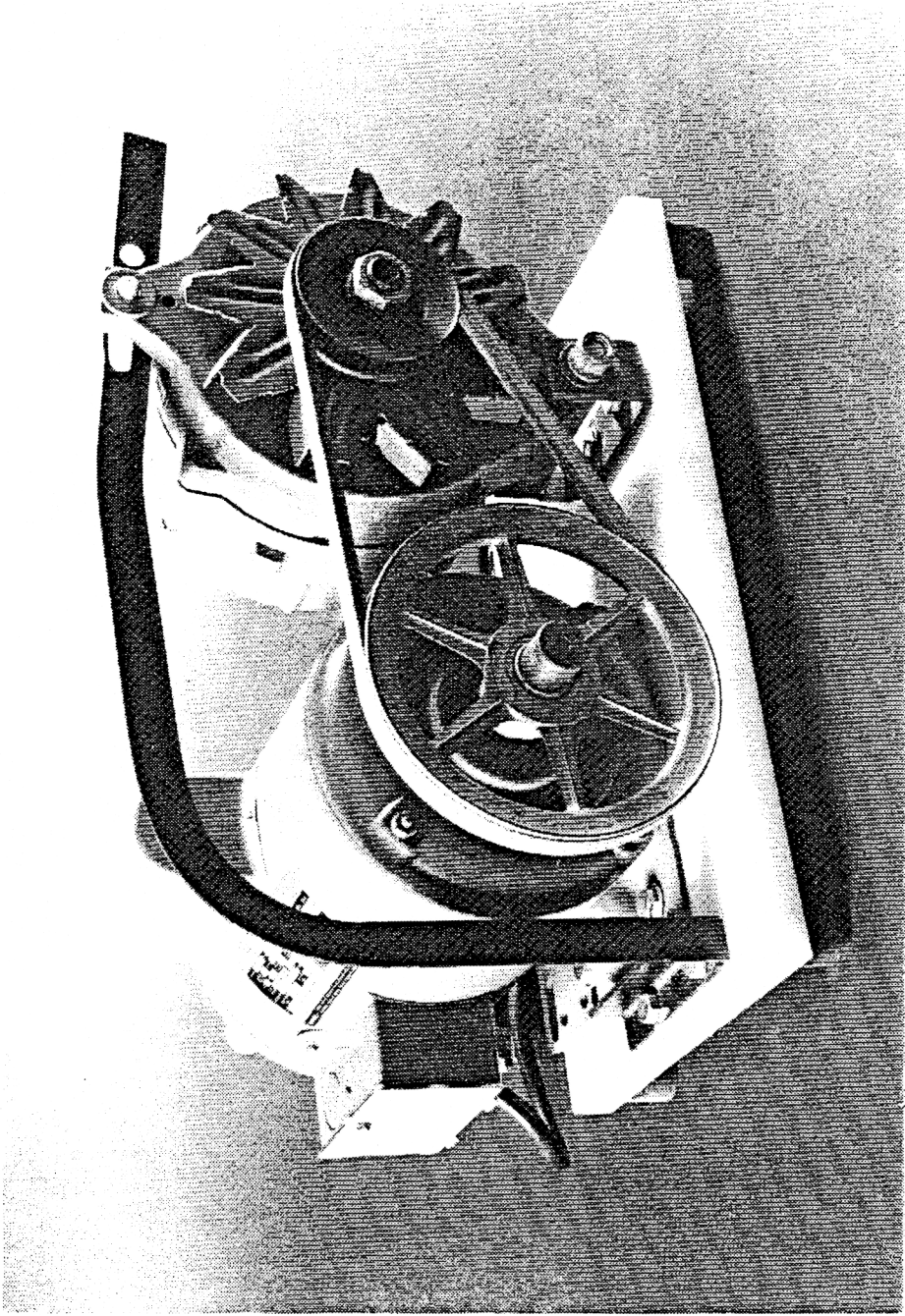
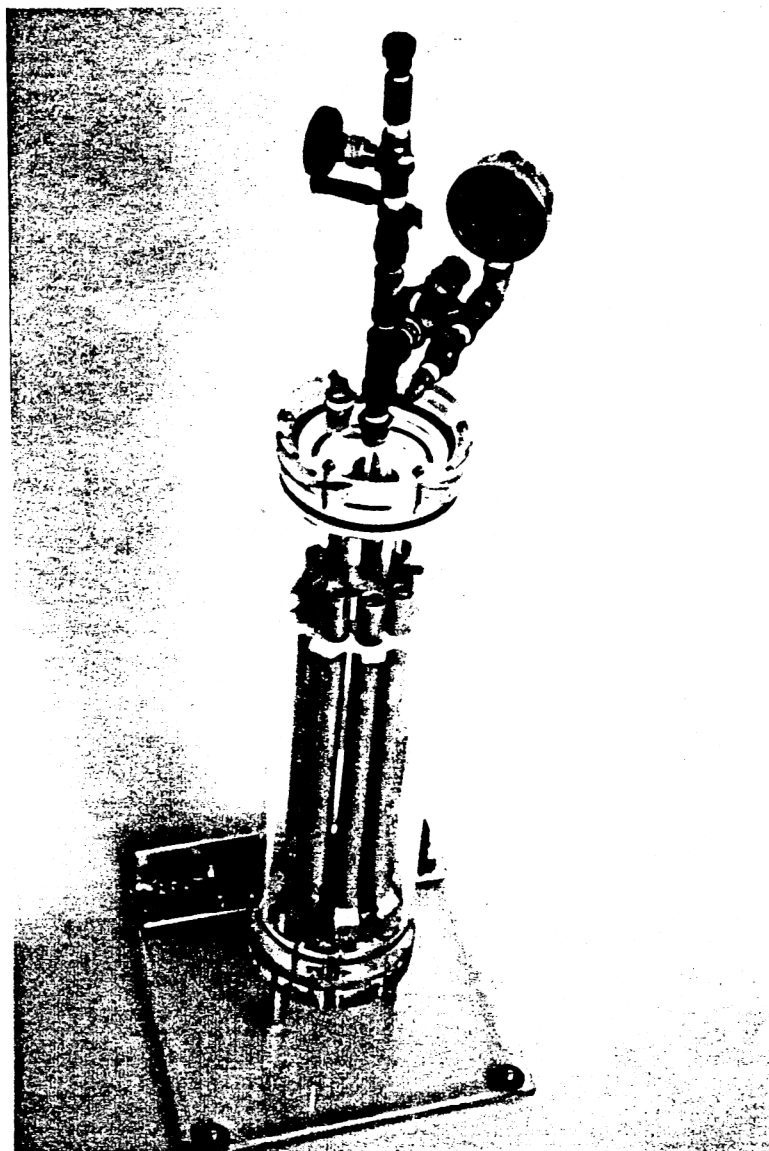

PHOTO EXHIBIT 11B1: ROTARY PULSE  
VOLTAGE FREQUENCY CONTROL UNIT  
0 -110VDC UNIPOLAR INPUT



**PHOTO EXHIBIT 11C: ROTARY PULSE VOLTAGE  
FREQUENCY GENERATOR ASS'Y**

EXHIBIT PHOTO E2A:



TUBULAR-ARRAY WATER FUEL CELL  
TEST-UNIT



SUMMARY REPORT

ON

TECHNICAL CHARACTERISTICS  
( GAS-SAMPLING/ GAS-RATE CONTROLLABILITY)

OF

NATURAL WATER HYDROGEN GENERATION SYSTEM  
(U.Ş. Patent S/N 6/302,807 filed Sept. 16, 1981)

FOR

PATENT VALIDATION, RECORDATION, AND PROCESSING

JANUARY 14, 1983

SUBMITTED TO:

Anthony D. Cennamo,  
Patent Att'y

PREPARED BY:

*Stanley A. Meyer* JAN 14, 1983  
Stanley A. Meyer Date

WITNESSED BY:

*Charles G. Holbrook* 1-14-83  
NAME DATE

FILE COPY  
ONLY  
DON'T REMOVE

*Stanley M. Grumbel* 1-14-83  
NAME DATE

ON MICROFILM

State of Ohio :  
                  : SS  
County of Franklin :

MARIE H. MEYER  
NOTARY PUBLIC, STATE OF OHIO  
BY COMMISSION EXPIRES AUG. 2 1984

Having appeared before me and known to me has made Oath  
that the statements of facts as recited are true.

Date: Jan 14 1983  
month, day, year

*Marie H. Meyer*  
NOTARY

SEAL



# R & D Laboratory

EXHIBIT A

January 10, 1963

## A Certified Biological Testing Laboratory

Dairy Products Mr. Stanley A. Meyer  
3792 Broadway  
Foods Grove City, Ohio 43123

Waters

Clinical Microbiology Analysis of Water Samples for sodium and potassium concentrations.

### Source of Water

<u>Source of Water</u>	<u>ppm</u>	
	<u>Sodium (Na)</u>	<u>Potassium (K)</u>
Drilled well Washington Court House, Ohio	20	4.0
Tap water	10	1.0
Rain water from Kroger roof in Washington Court House, Ohio	15	1.1
Lake Mount Sterling	17	3.2
Ohio River	40	5.0
Ocean Salt Water	25,000	1100.0
Distilled Water	<1	<1.0

Sodium concentrations in natural water varies greatly from almost nothing to 70 ppm. Potassium, however, in natural waters seldom exceeds 20 ppm. Ocean salt water is normally much higher in concentration than natural fresh water sources.

Respectfully submitted,

*Thomas Bell*

C. Thomas Bell, Ph.D.  
Laboratory Director

ON MICROFILM

FILE COPY  
ONLY  
DON'T REMOVE

Analysis performed by aa spectrophotometer method.

Analysis performed and certified by the above signed.

Analysis Since 1949

2331 Sullivant Avenue  
Columbus, Ohio 43204  
(614) 274-6467

# Analytical Research Associates, Inc.

3274 Maize Road • Columbus, Ohio 43224

Telephone (614) 267-0279

RESEARCH • ANALYSIS • CONSULTATION • STAFF TRAINING

January 11, 1983

Water Fuel Cell  
3792 Broadway  
Grove City, Ohio 43123

Ref: A-3870  
A-3878

Attn: Mr. Stanley A. Meyer

Subject: Analysis of Gas Samples Received December 6, 1982 and  
January 10, 1983

Sample	Oxygen	Volume % Nitrogen	Hydrogen	BTU Value*
River Water	24.7	29.3	46.0	150
City Tap Water	29.5	9.9	60.6	196
Well Water	27.9	8.0	64.1	208
Lake/Reservoir Water	30.0	4.1	65.9	214
**Distilled Water	30.7	16.7	52.7	171
**Ocean Water	19.3	12.1	68.6	223
**Rain Water	32.0	9.6	58.4	190

\* BTU Value(calculated) Calories/cubic foot at 60°F & 760mmHg  
\*\*Gas samples retested for analytical accuracy

Analysis by gas chromatographic method.  
Analysis performed and certified by the below signed.

Respectfully submitted,

  
Susan Morris

infrared spectroscopy • vapor phase chromatography • environmental analysis

# R & D Laboratory

EXHIBIT A

A Certified Biological Testing Laboratory

FILE COPY  
ONLY  
DONT REMOVE

Dairy Products

Foods

Waters

Clinical  
Microbiology

## BIOGRAPHICAL RECORD

C. THOMAS BELL, Ph.D.

ON MICROFILM

Laboratory Director  
R & D Laboratory

### I. EDUCATION

- A. Ph.D., Physiology and Microbiology, College of Agriculture, The Ohio State University, 1979
- B. M.S., Physiology and Nutrition, College of Agriculture, The Ohio State University, 1974
- C. B.S., Production Agriculture, College of Agriculture, The Ohio State University, 1972.

### II. PROFESSIONAL AFFILIATIONS

- A. American Society of Animal Scientist
- B. American Society of Agricultural Engineers
- C. Association of Official Analytical Chemists
- D. Ohio Association of Milk, Food and Environmental Sanitarians
- E. Ohio Valley Food Technologists

### III. EXPERIENCE

- A. Laboratory Director of R & D Laboratory, a certified biological testing laboratory, providing analysis of foods, dairy products, meats, waters and waste waters microbiologically and chemically. While R & D Laboratory under the direction of Dr. Bell is certified by the Ohio EPA and Ohio Department of Health the laboratory provides analysis and inspections for industry's own quality assurance programs.
- B. President and General Manager of Bell Energy Laboratories, Inc. Involved with planning the engineering of energy management; developing cost effective programs to meet current needs; incorporating solar application; utilizing geothermal energy as supplementary heating; agricultural management and energy consultation.

Analysis Since 1949

2331 Sullivant Avenue  
Columbus, Ohio 43204  
(614) 274-6467

# R & D Laboratory

EXHIBIT A

A Certified Biological Testing Laboratory

FILE COPY  
ONLY  
DON'T REMOVE

Dairy Products      Biographical Record  
Foods                C. Thomas Bell, Ph.D.  
Waters                Page Two

Clinical  
Microbiology

### III. EXPERIENCE

ON MICROFILM

- C. As Assistant Professor in the Ohio State University Cooperation Extension Service dealt with problems of production of agronomic crops. Consultation on aspects of soil fertility, crop selection and cultural practices needed to improve crop production was given. Management of Pest Management Program, which included weekly surveys of crops and the reporting of disease, weed and insect pests was provided to crop producers with recommendations to control these problems. The coordination of the municipal sludge application to agricultural land research project was undertaken to study the effects of sludge on crops, and fertility and health aspects to humans and livestock.
- D. Additionally, Dr. BELL has served on the Franklin County Agricultural Stabilization and Conservation Service, Soil Conservation Service, Ohio Department of Agriculture, and the United States Department of Agriculture helping to solve problems that occur in crop production and soil fertility and reporting of environmental conditions that affect crop production.

Analysis Since 1949

2331 Sullivant Avenue  
Columbus, Ohio 43204  
(614) 274-6467

**SUMMARY REPORT**

**ON**

**TECHNICAL CHARACTERISTICS  
OF  
STAINLESS STEEL  
FOR  
CERTAIN CONDITIONS**

**DECEMBER 22, 1982**

**FILE COPY  
ONLY  
DON'T REMOVE  
  
ON MICROFILM**

**PREPARED BY:**

**COL-X CORPORATION  
MATERIALS JOINING CONSULTANTS DIV.  
981 EAST HUDSON STREET  
COLUMBUS, OHIO 43211**

# **Materials Joining Consultants**

Welding Engineering and Inspection  
 981 E. Hudson Street · Columbus, Ohio 43211 · (614) 267-1201

December 22, 1982

**FILE COPY  
ONLY  
DONT REMOVE**

Mr. Stanley A. Meyer  
 3792 Broadway  
 Grove City, OH 43123

**ON MICROFILM**

Dear Mr. Meyer:

**SUBJECT: TECHNICAL CHARACTERISTICS OF STAINLESS STEEL FOR CERTAIN CONDITIONS**

A spectographic chemical analysis of the 0.50-inch and 0.750-inch outside diameter tubing samples provided to the offices of Materials Joining Consultants has been performed. The results of this chemical analysis and other supporting material characteristics are summarized in this report.

The tubing material can be classified as a general purpose austenitic type 304 Stainless Steel. 304 is considered the standard or basic 300 series stainless steel alloy. The material is austenitic, face-centered cubic, and paramagnetic. Many of the other 300 alloys such as the acid resistance 316 stainless are modifications of the 304 material. The 300 series is known for its good notch toughness.

The results of the chemical analysis are presented below:

<u>Element</u>	<u>% Composition</u>	
	<u>0.50-Inch</u>	<u>.750-Inch</u>
Iron	72	70
Carbon	.063	.041
Manganese	1.36	1.62
Phosphorus	.025	.034
Sulfur	.016	.001
Silicon	.53	.55
Copper	.14	.15
Tin	.010	.013
Nickel	8.21	9.14
Chromium	18.2	19.3
Molybdenum	.08	.14
Aluminum	.002	.012
Vanadium	.07	.07
Columbium	.009	.014
Zirconium	.003	.004
Titanium	.001	.005
Boron	.0004	.0007
Cobalt	.12	.10
Tungsten	.00	.01

In addition to the chemical analysis performed, an analysis of several water samples for sodium and potassium concentrations was conducted. The work as performed by R & D Laboratory and summarized in a letter dated November 12, 1982 was provided to Materials Joining Consultants for review. A synopsis of the analysis follows:

A Division of  Corporation

Mr. Stanley A. Meyer

December 22, 1982

2

<u>Source of Water</u>	<u>Concentration in PPM</u>	
	<u>Sodium (Na)</u>	<u>Potassium (K)</u>
(1) Drilled well, Washington Court House, Ohio	20	4.0
(2) Tap water, Washington Court House, Ohio	10	1.0
(3) Rain water from Kroger roof in Washington Court House, Ohio	15	1.1
(4) Lake Mount Sterling, Ohio	17	3.2

The austenitic type 304 is manufactured so as not to substantially oxidize, corrode, decompose, or deteriorate more than what is presented below: (1) (2)

- A. When immersed in natural water, such as tap, river, sea, well, or rain and having a potassium and sodium content no greater than that presented by R & D Laboratory will not corrode more than 0.0007 inches per year.
- B. When immersed in natural water as aforesaid, and exposed to oxygen atoms in said water will not corrode more than 0.0001 inches per year.
- C. When immersed in natural water as aforesaid, and exposed to hydrogen atoms in said water will not corrode more than 0.0001 inches per year.
- D. When immersed in natural water as aforesaid, and exposed to both hydrogen and oxygen atoms in said water will not corrode more than 0.0001 inches per year.
- E. When immersed in water as aforesaid, and having a voltage/very low current applied thereto will lose very little metal.
- F. When immersed in water as aforesaid, and having both hydrogen and oxygen atoms in said water and with a voltage/very low current electrical power applied thereto will lose very little metal.

Should you have any questions concerning the work performed or require any further assistance, please contact Mr. Scott Anderson or myself.

Respectfully Submitted:

MATERIALS JOINING CONSULTANTS

FILE COPY  
ONLY  
DONT REMOVE

ON MICROFILM

  
Robert L. Queen, Staff Engineer

RLQ:1b

Analysis performed by a spectrographic method.

Analysis performed and certified by the above signed.

- (1) Polar, J. P., A Guide to Corrosion Resistance, (Greenwich, Conn.-Climax Molybdenum Company, 1981).
- (2) Fontana, M. G., Greene, N. D., Corrosion Engineering, (New York, N.Y.-

AFFIDAVIT OF ROBERT L. QUEEN

Robert L. Queen, being duly sworn deposes and says, that he is a staff engineer with Materials Joining Consultants, doing business at 981 East Hudson Street, Columbus, Ohio, 43211, and that:

1. material samples of 0.50 and 0.75 inch outside diameter tubing as per attachment B and identified therein as stainless steel T-304 was supplied by Stanley A. Meyer;
2. it was requested that Materials Joining Consultants conduct a chemical analysis of the material and to provide other supporting information;
3. the chemical analysis was conducted and the result as stated in attachment A are true and accurate;
4. an analysis of several water samples for sodium and potassium as conducted by R & D Laboratory also was provided for review;
5. thereafter an analysis was conducted as to affects of the aforesaid water on the austenitic type 304 stainless steel; and that
6. the results of the analysis as given on the second page of attachment A is true and accurate.

FURTHER AFFIANT SAETH NOT.

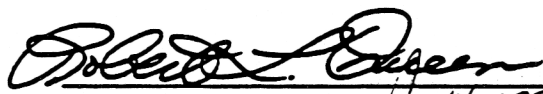
  
 Robert L. Queen *Jan 14, 1983*

County of Franklin )  
 ) ss  
 State of Ohio )

The above-named Robert L. Queen personally known to me, did appear before me and make Oath that the statement of facts as recited in his Affidavit are true.

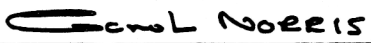
  
 Notary *1/14/83*  
 CAROL NORRIS  
 NOTARY PUBLIC, STATE OF OHIO  
 MY COMMISSION EXPIRES NOV 30, 1984

SEAL



AVERAGE PHYSICAL PROPERTIES OF PLEXIGLAS SHEET

PROPERTY	ASTM METHOD <sup>2</sup>	UNITS	TYPE		
			Plexiglas G and II UVA	Plexiglas K	Plexiglas 55
<b>ELECTRICAL</b>					
Dielectric Strength, Short Time Test	D149	volts/mil	500	>430	530
Dielectric Constant	D150				
60 Hz			3.7	3.6	3.9
1,000 Hz			3.3	3.4	3.4
1,000,000 Hz			2.5	3.0	2.1
Power Factor	D150				
60 Hz			0.05	0.06	0.05
1,000 Hz			0.04	0.05	0.04
1,000,000 Hz			0.03	0.02	0.03
Loss Factor	D150				
60 Hz			0.19	0.22	0.20
1,000 Hz			0.13	0.15	0.14
1,000,000 Hz			0.08	0.06	0.07
Arc Resistance	D495		No Tracking	No Tracking	No Tracking
Volume Resistivity	D257	ohm-cm.	$6 \times 10^{17}$	$6 \times 10^{17}$	—
Surface Resistivity	D257	ohm/square	$2 \times 10^{18}$	$2 \times 10^{18}$	—
<b>MISCELLANEOUS</b>					
Flammability (Burning Rate)	D635	in./minute	1.1°	1.3°	0.5°
Water Absorption, 24 Hrs. at 73°F.	D570				
Weight Loss on Drying		%	0.1°	—	0.2°
Weight Gain on Immersion			0.2°	—	0.2°
Soluble Matter Lost			0.0°	—	0.0°
Water Absorbed			0.2°	—	0.2°
Dimensional Changes on Immersion			0.0°	—	0.0°
Water Absorption to Saturation	D229				
Weight Gain After Immersion	and D570	%			
1 Day			0.2°	0.3°	0.2°
5 Days			1.1°	1.5°	1.6°

Refer. Data: Dayton Plastic " Plastic Engineering Handbook" Jan. 1979

FILE COPY ONLY  
DONT REMOVE

ON MICROFILM

AFFIDAVIT OF RELATING TO TECHNICAL CHARACTERISTICS  
OF NON-CHEMICAL HYDROGEN GAS GENERATION SYSTEM

Robert L. Ward , being duly sworn deposes and says that he has been a chemist for over 27 years, and that he has the education background and technical experience to make him knowledgeable as to the characteristics of hydrogen gas generation testing under given conditions; and that said education comprises:

B.S. Degree in Chemistry 1955  
Morehead State University  
Morehead Ky.

and said background and technical experience comprises:

EMPLOYED BY: Allied Chemical Corp. for 23 Years as  
analytical and R&D chemist:

8 years at South Point, Ohio

Chief Chemist & Lab Supervisor 15 years, Ironton, Ohio

EMPLOYED BY: Ironton Coke Corp. for 4 years as  
Corp. Technical Director Ironton, Ohio

Affiant further states, that

A) Performed the test and sampling of gases derived from natural water having a potassium and sodium content no greater than that specified in the attached Exhibit A; and that,

B) The above said gas samples were derived and/or generated from the following types of natural water sources via the non-chemical hydrogen generation system ; and that

- 1) Distilled Water
- 2) Rain Water
- 3) Lake/ Reservoir Water
- 4) City Tap Water
- 5) River Water
- 6) Well Water (as; softened)
- 7) Ocean Water

- C) That only non-oxidizing materials (stainless steel #304 ) were immersed in the above said non-chemical hydrogen generation system during the above said gas test sampling; and that,
- D) The above said non-chemical hydrogen generation system housing consists of non-oxidizing material-clear Acrylic material;

AFFIANT FURTHER SAETH NOT.

Witnesses :

Robert L. Ward  
December 2, 1982

Stanley A. Meyer 12/2/82

Stanley M. G. ... 12/2/82

Charles C. ... 12-2-82

State of Ohio :  
                  : SS  
County of       :

Having appeared before me and known to me has made Oath that the technical facts stated above are based upon technical expertise and opinion and true or believed to be true.

Marie H. Meyer  
12-2-82

Notary

MARIE H. MEYER  
NOTARY PUBLIC, STATE OF OHIO  
MY COMMISSION EXPIRES AUG. 2 1983

Seal

WATER COLLECTION/TEST OBSERVATION AFFIDAVIT  
STANLEY GRAUMLICH AND CHARLES C. HOLBROOK

Stanley Graumlich, residing at 3672 State Route 62 N.E.  
Washington Court House, Ohio 43210, and

Charlie C. Holbrook, residing at 4907 State Route 41 N.W.  
Washington Court House, Ohio 43160.

being duly sworn depose and say: that

1. they are personally known to Stanley A. Meyer and have assisted him in conducting tests on said hydrogen generator system ( U.S. patent serial number 6/302,807 filed on 9/16/1981) for patent recordation and processing since July 1981;and that,
2. they are familiar with the contents and disclosure in U.S. patent application Serial Number 6/302,807 filed 9/16/81 by Stanley A. Meyer on said Hydrogen Generator System; and that,
3. through association of Affiants with Stanley A. Meyer and their continued assistance in conducting tests on said Hydrogen Generator System, Affiants are with knowledge that any type of natural water (as per Exhibit A) is totally operable in said Hydrogen Generator System, that the non-oxidizing similar material "plates" (as per Exhibit B) are made of stainless steel tubing or other configuration of stainless steel material (Exhibit E), and the D.C. electrical potential (constant or pulsed, Exhibit E) applied to said non-oxidizing "plates" (Exhibit B) is a voltage with only a minimum current to sustain a potential; and that
4. for patent recordation and processing, they were requested by Stanley A. Meyer to obtain containers of natural water (as per Exhibit A) from different natural water sources and to personally

FILE COPY  
ONLY  
DONT REMOVE ON MICROFILM

deliver said water containers with said natural water (Exhibit A) to R & D Laboratory for analysis; and that

5. they were also requested by Stanley A. Meyer to personally deliver said non-oxidizing "plate" material (Exhibit B) to Col-X Corporation for analysis ; and that,

6. they were also requested by Stanley A. Meyer to personally purchase (Exhibit J) said non-oxidizing housing (Exhibit E) Mat'l (clear acrylic plastic material, as per Exhibit C) for gas-sampling (Exhibit F); and that,

7. affiants ( Charles C. Holbrook/ Stanley Graumlich) obtained said natural water (Exhibit A) ie., distilled water, rain water, river water, city tap water, well water, lake/reservoir water, an ocean water (as per Exhibit A) and seperately placed each type of natural water in containers of non-oxidizing material (sealed 5 gallons plastic buckets) marked as to its contents; and that

8. the marked containers of natural water (Exhibit A) were deliver by Affiants to the R & D Laboratory for analysis as to content, as per attached report - Exhibit A; and that,

9. portion of the natural water (Exhibit A) were taken from each of the sealed containers and placed in specially marked bottles by the director of the R & D Laboratory, the bottles were marked as to the types and source of the water as per Exhibit A; and that,

10.the natural water remaining in the 5 gallon containers were taken immediately and directly to the home testing laboratory of Stanley A. Meyer for generation of gasses from each of said types of natural water (Exhibit F) by Affiants in the present of said Stanley A. Meyer and said Robert L. Ward; and that,

ON MICROFILM

FILE COPY  
ONLY  
DON'T REMOVE

11. each 5 gallon container of said natural water (Exhibit A) was seperatedly poured into said Hydrogen Generator System (Exhibit E) having a housing of non-oxidizing material (Exhibit C) and which housing had an array of non-oxidizing stainless steel "plates" (Exhibit B) position therein (Exhibit E), the housing was sealed and a direct voltage/low current (constant or pulsed, Exhibit E) potential applied to said non-oxidizing "plates" (Exhibit B); and that,

12. Affiants witnessed the gas test-sampling (generation of Hydrogen gas, Exhibit G) conducted by Stanley A. Meyer and Robert L. Ward, R & D chemist (Exhibit F) with the use of each type of natural water (Exhibit A) in said Hydrogen Generator system (Exhibit E); and as observed by Affiants the test results conforms to the data submitted herein in the Affidavit of said Robert L. Ward (Exhibit F and Exhibit G); and that,

13. Affiants further witnessed the collection of said gas-samples (Exhibit G) from each type of natural water (Exhibit A) in said Hydrogen Generator system (Exhibit E); the gases collected (Exhibit G) were placed in seperate containers (specially prepared via Analytical Research Associates Inc., Exhibit G) appropriatedly marked as to the source of natural water (Exhibit A) by said Robert L. Ward (Exhibit F); and that,

14. Affiants further witnessed the delivery of said samples of gases (7 individually sealed containers, Exhibit G) directly to Analytical Research Associates, Inc. by said Robert L. Ward and said Stanley A. Meyer for analysis as to gas content of each of said samples - Exhibit G); and that,

15. Affiants witnessed the initial tests conducted on said collected gas samples (Exhibit G) by the personnel of the Analytical Research Associates, Inc.; and that,

ON MICROFILM FILE COPY  
ONLY REMOVE

AFFIANTS further state: that

16. Affiants witnessed the Hydrogen Gas Control-rate evaluation-testing by Stanley A. Meyer and Stephen F. Meyer, R & D Electron Design Engineer (Exhibit H), with the use of the various types of natural water (Exhibit A) in the Hydrogen Generator (Exhibit E-HG 1004/HG 1005, HG 1006); and as observed by AFFIANTS the test results conforms to the test-data submitted herein in the Affidavit of said Stephen F. Meyer (Exhibit E); and that,  
FURTHER AFFIANTS SAETH NOT.

Charles C. Holbrook 1-14-83  
CHARLES C. HOLBROOK      DATE

Stanley M. Graumlisch 1-14-83  
STANLEY GRAUMLICH      DATE

WITNESSED BY:

Stanley A. Meyer 1/14/83  
STANLEY A. MEYER      DATE

ON MICROFILM

FILE COPY  
ONLY  
DONT REMOVE

The above-name Stanley A. Meyer, Charles C. Holbrook, and Stanley Graumlisch, personally known to me, did appear before me and make Oath that the statement of facts as recited in the above AFFIDAVIT are true.

MARIE H. MEYER  
NOTARY PUBLIC, STATE OF OHIO  
MY COMMISSION EXPIRES AUG. 2 1983

Marie H. Meyer  
NOTARY



CHARLES HOLBROOK & STANLEY GRAUMLICH  
COLLECTING NATURAL WATER (EXHIBIT D)

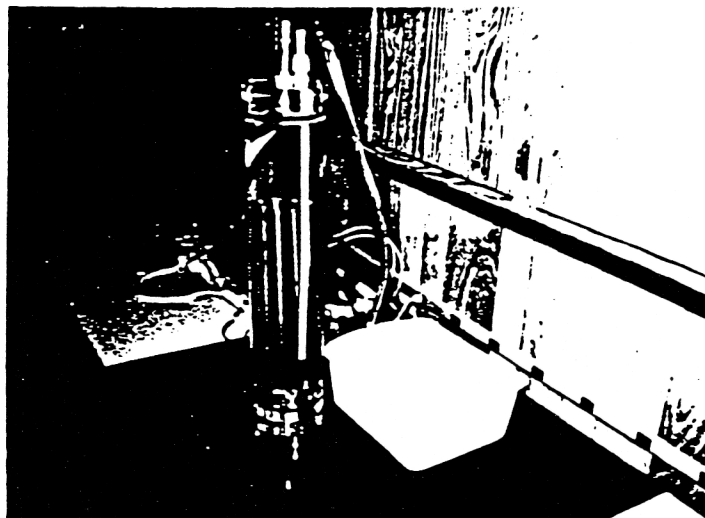

HYDROGEN GAS-TEST APPARATUS  
TUBULAR-ARRAY (HG1005)





ROBERT L. WARD, CHARLES HOLBROOK  
PERFORMING HYDROGEN GAS-SAMPLING  
TEST OF DISTILLED WATER (SEE EXHIBIT F)

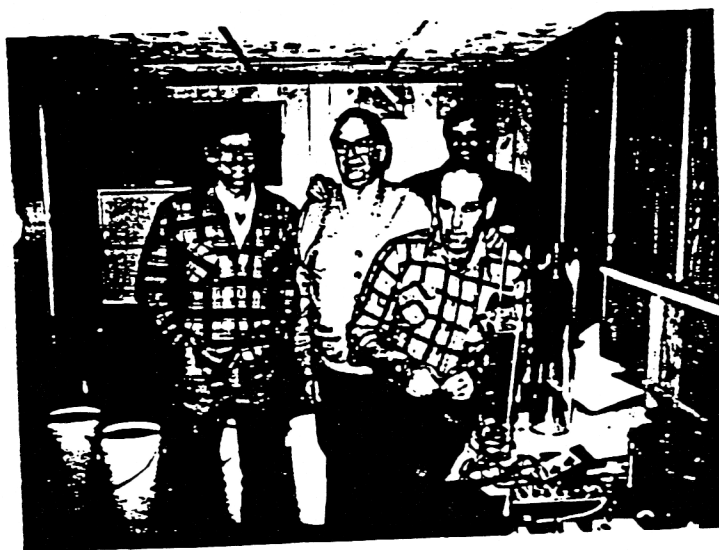

GAS-TEST OBSERVERS: STEPHEN F. MEYER,  
STANLEY GRAUMLICH, CHARLES HOLBROOK,  
STANLEY A. MEYER (LEFT TO RIGHT)

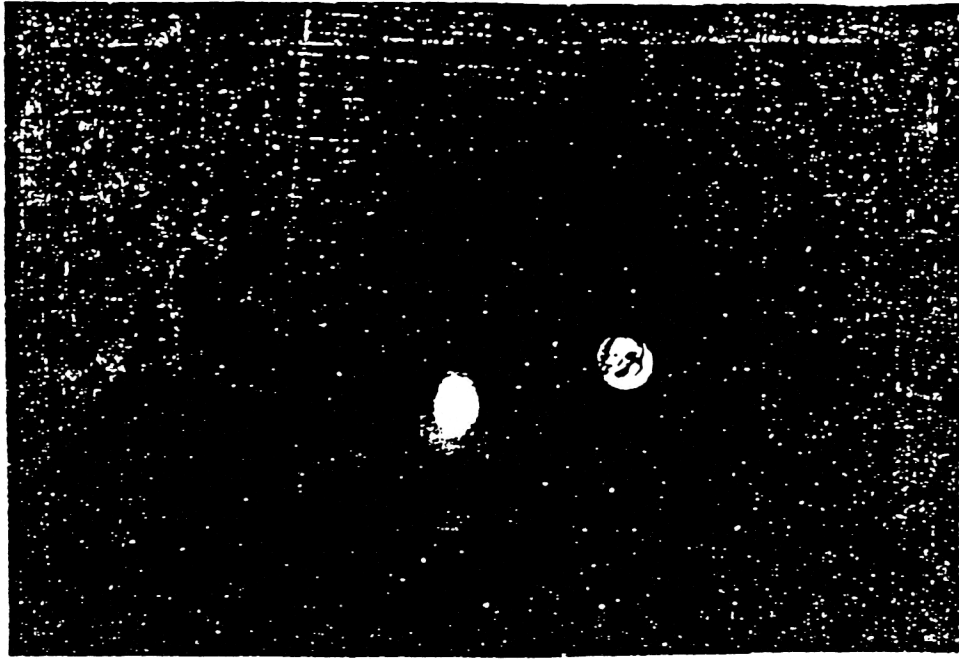

CONSTANT AND SUBSTAINED HYDROGEN GAS-FLAME AT THE RATE OF HYDROGEN GAS- PRODUCTION DURING LOW VOLTAGE STIMULATION: 0.5 INCH HIGH FLAME



CONSTANT AND SUBSTAINED HYDROGEN GAS-FLAME AT THE RATE OF HYDROGEN GAS PRODUCTION DURING VOLTAGE STIMULATION: MELTING STAINLESS STEEL 12 Ga WIRE MATERIAL : FLAME TEMPERATURE 2500 DEGREES F PLUS

**Electrical Polarization Process (EPP)  
Voltage Dissociation of the Water Molecule**

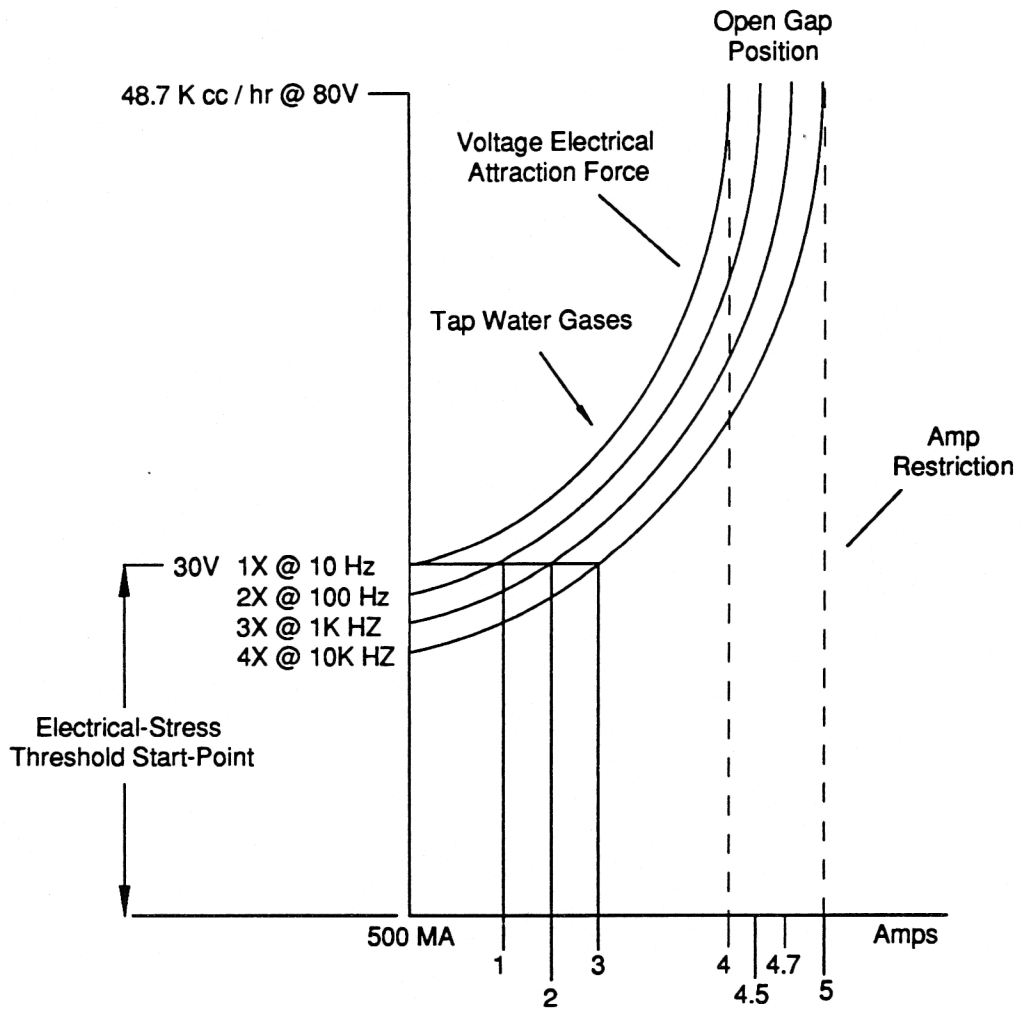

**Variable Flat-Plate (Water Fuel Cell) (E1A)  
Solid State Amp Inhibiting Circuit (8XA)**

**Test Equipment:**  
 TIF Instruments: 1000 DC Digital Clamp-on Connectionless Ammeter  
 Micronta Model 22-210 - DC Volt Meter

## Rotary Pulse-Voltage Alternator

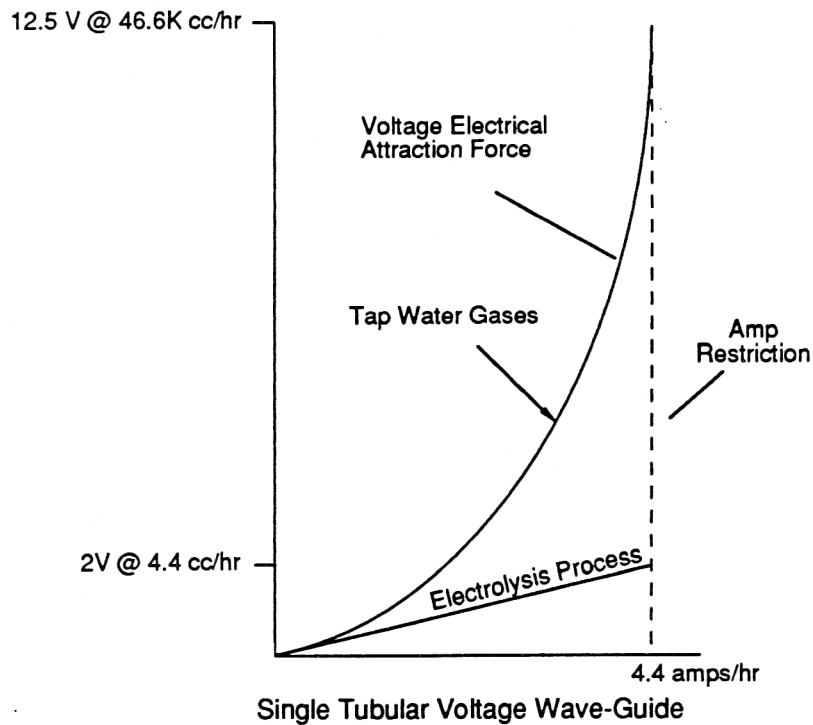

## Voltage Dissociation of the Water Molecule Tubular-Array (Water Fuel Cell) (E2A)

- 1) Tested Electrical Power Loading: 12.5VDC @ 40 amps = 500 watts
- 2) Tested Gas Rate: 1 liter cavity @ 7lbs / min Gas Production Rate
- 3) 1 Liter Cavity = 1,000 cc of Gas Volume = 1lb Gas Pressure
- 4) 1,000 cc X 7lbs / Min = 7,000 cc Gas Volume / min.
- 5) 7,000 cc / min X 60 minutes = 420,000 cc / hr. Gas Production Rate
- 6) 420,000 cc / hr. + 9 Tubular Voltage Wave-Guides = 46,666 cc / hr/ tube
- 7) Electrical Watts per tube: 12.5V x 4.4 amps / hr = 55 watts / hr

Prior Art "Electrolysis": Electrolyte 20% per liquid volume; Dead Short Condition

- 8) 1 cc Gas Production Rate per (1) amp / hr @ 2 Volts Electrical Power Loading
- 9) Electrical Watts: 4.4 amps / hr x 2 Volts Potential = 8.8 Watts / hr
- 10) Total Gas-Yield: 1cc x 4.4 amps / hr = 4.4 cc / hr Gas Production Rate

Electrical Polarization Process (EPP) Vs Prior Art Electrolysis Process

- 11) 55 Watts / hr (EPP) + 8.8 Watts / hr (Electrolysis) = 6.25 X 4.4 cc / hr = 27.5 cc / hr. estimated gas-yield (Electrolysis).

Therefore,

- (12) 46,666 cc / hr + 27.5 cc / hr = 1,696 WFC Differential Efficiency Factor greater than Electrolysis.

Test Equipment:

TIF Instruments: 1000 DC Digital Clamp-on Connectionless Ammeter  
Micronta model 22-210 DC Volt Meter

Electrical Polarization Process (EPP)  
Voltage Dissociation of the Water Molecule

Continuation ... Tubular-Array

Hydrogen Content of Gas:

13) 46,600 cc/hr (EPP) gas-yield - 5,126 cc/hr (11% ambient air) = 41,474 cc/hr

14) 41,474 cc/hr x 20 % (\* hydrogen mass unit of Water) = 8,294.8 cc/hr hydrogen content of gas

\* Mass Unit of Water Molecule = (2H x 1Mu) + (1 Oxy x 8 Mu) = 10 Mu's

2 H Mu + 10 Mu's = 20%

(See WFC The Birth of New Technology, Table of Tabulation, Appendix A).

Therefore

15) 8,294.8 cc/hr ÷ 27.5 cc/hr = 301 (WFC Differential Efficiency Factor) (DEF) greater than Electrolysis (See Dr. T. Nagypal Test-Report, WFC International Independant Test-Evaluation manual.

## Table of Tabulations

- Tab 33) Calculation on using "Mass Unit" to determine the amount of hydrogen contained in a gallon of Water.
- Tab 34) Calculation on using "Mass Unit" to determined the amount of hydrogen contained in a gallon of Gasoline.
- Tab 35) Calculation on using "Mass Unit" to determined the amount of hydrogen contained in a pound of Natural Gas vs. Water.
- Tab 36) Calculation on using "Water as Fuel" to run a 50 hp I.C. Engine as compared to Gasoline.
- Tab 37) Calculation on determining the liquid-volume of a "Water Droplet" per injection cycle.
- Tab 38) Calculation on determining the electrical power input required to electrically energize the Voltage Intensifier Circuit per injection cycle.
- Tab 39) Calculation on determining the liquid-volume of a "Water Droplet" required to run a 1000 Bhp I.C. Engine per injection cycle.

Application Notes

## Water vs. Fossil-Fuel Energy Content

Water is composed of (2) Hydrogen Atoms and (1) Oxygen Atom to form a molecule of Water.

(Tab 33)

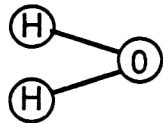

Atomic Mass Unit:

1 Electron (E) = 1 Proton (P) ~ 1Mu

Hydrogen Atom: 1E = 1P ~ 1Mu

Oxygen Atom: 8E = 8P ~ 8Mu

Atomic Mass Ratio (Mur) of Water

(2H X 1Mu) plus (1 Oxy. X 8 Mu) = 10 Mu's

**\*\* See Appendix (B) Note (2)**

Whereby,

2H (Mu) divided by (10 Mu's) = 20%

Thus,

One gallon of Water contains 1.669 lbs.  
of Hydrogen

Molecular Structure of Water  
(Volumetric Displacement of Atom spheres)

## Energy-Yield Potential of Water

One water gallon equals 8.345 lbs

8.345 lbs x .20 = 1.669 pounds of Hydrogen / H<sub>2</sub>O gal.

1.669 pounds of hydrogen-fuel of water - .18359 lbs (11% per volume of impurities ...

typically 20 ppm ~ 40 ppm contaminates with Ambient Air being present ) =

1.4854 lbs of hydrogen atoms available for gas combustion per gallon of Water approximately.

## Water as Fuel ®

The by-product of burning gases derived from Water is environmentally safe since there is no carbon atoms present in the Water molecule ... resulting in the re-formation of Water "mist" after gas combustion ... being able to re-energize the newly formed Water Droplets for energy "reuse" once exposed to Sunlight. (See Energy recycling graph 530 of Figure 5-6, once again)

Natural Gas is composed of (5) carbon atoms and (12) hydrogen Atoms to form a molecule of gas.

(Tab 35)

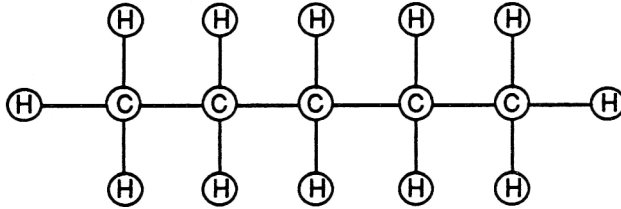

Molecular Structure Of Natural Gas  
(Volumetric Displacement of Atom spheres)

Atomic Mass Unit:

1 Electron (E) = 1 Proton (P) ~ 1 Mu

Hydrogen Atom: 1 E = 1P ~ 1Mu

Carbon Atom: 6 E = 6P ~ 6 Mu

Atomic Mass Ratio (Mur) of Natural Gas:  
(12H x 1 Mu) plus (5C x 6Mu) = 42Mu's

\*\* See Appendix (B) Note (2)

Whereby

12H (Mu) divided by 42 (Mu's) = 28% of gas pound (lb).

Thus,

One pound (lb) of Natural Gas contains  
.28 lb of Hydrogen Atoms

Fuel Gas Contaminates: Cryogenic Processing:

12% Non-burnable Contaminates (carbon dioxide, heavy hydrocarbons, and Water vapor)

.28 lbs of hydrogen atoms x 12% = .28 lbs - .033 = .247 lbs Hydrogen atoms

Energy-Yield Potential:

.247 lbs hydrogen atoms - 10% (absorption Contaminates) = .247 - .024 = .223 lbs of hydrogen atoms available for gas combustion per pound of Natural Gas approximately.

Thereby

As to Normal Gas Burning Levels, One pound (1) lb of water contains approx. (.185) lbs of Hydrogen Atoms as compared to One pound (1) lb of Natural Gas which contains approx. (.223) lbs of Hydrogen Atoms. Water, of course, supplies its own oxygen to support the combustion process; whereas, Natural Gas must extract oxygen from air to produce thermal heat.

Energy Enhancement Process:

Energy Yield Enhancement of water is increase beyond Natural Gas burning rate by way of the Hydrogen Fracturing Process which simply prevents and/or retards the formation of the water molecule during thermal gas ignition/combustion... Energy priming the combustible gas atoms by stimulating the Atomic Energy Balance of Water (memo WFC 424) undergoing "Voltage Tickling of State Space" ...to cause "Particle Oscillation" as a "Energy Generator".



---

Note 1) The Electron Inhibiting Effect (631) of Figure (7-6) to cause "Electron Clustering" (Grouping/collecting negative charged particles at a given point) (700) of Figure (7-9) to produce "Negative Voltage Potential" ( B- ) at one side of Water Gap (Cp) of Figure (7-8) is accomplished by low electrical power input ( Tab 38) when Choke-Coil (62) of Figure (7-1) magnetic field (FL2) (690) of Figure (7-8) during pulse on-time (49) impede "Electron-Flow" since electron mass is composed of electromagnetic matter which interacts with magnetic field strength (FL2). Capacitance Charging Effect (628) prevents amp influxing away from Water Gap (Cp) in a similar manner ... producing "Electrical Stress" (SS' ~ RR') (B+/B-) across Water Gap (Cp) since both Choke-Coils (56/62) conducts voltage potential (Negative or Positive) during pulsing operations.

Note 2) In determining volumetric sizing of the atom, Neutrons Clustering only enlarges the nucleus surface area since the additive Neutron (s) exhibits no electrical charge to deflect or change the orbital spin-velocity of the atom electrons.

Note 3) Universal Energy (9) of Figure (5-10) being a continuous energy potential (source) (C<sup>2</sup>) coming into our space continuum and creating and sustaining/maintaining our expanding universe, as so extrapolated via mass equation  $E=MC^2$ . Whereby, Universal Energy (C<sup>2</sup>) having native intelligence to create mass (M) (to cause electromagnetic wave-vectoring ~ photon structuring ~ electron to proton grouping to form atoms ~ molecular arrangements to bring-on chemical processes to sustain life) which, in turns, emits radiant energy (E) under different stimuli conditions ... example, particle oscillation as a energy generator by way of "Electrical Stress".

Dr T.Nagypal  
Schulzg.15/6  
A -1210 Wien  
Austria/Europe

Tel: (0222)-743-521-280  
Fax: (0222)-743-521-289  
Private: (0222)-306-483

Vienna, 04.June 1991

Stanley A.Meyer  
Director of WFC.Inc.  
3792 Broadway  
Grove City, Ohio 431 23  
USA.

Dear Mr. Stanley R.Meyer,

I have had a good day, on 3.May, 1991 - received your answer and enclosed WFC patent references.  
Thank You very very mutch !!!!!

Since this, I am working exclusively on the laboratory-model. My model works with the simplest plan-parallel excitor plates, consumes about 20 mA and produces about 0.5-1 cubic centimeter gas, from tap water, however a can't reproduce of yours excitor's waweforms. (I haven't namely the mentioned "arcadic" potential-wawe-forms, but I got a rising step-wawe-formed current-pulses, between the plates appears only some millivolt potential difference, due to water's resistance, caused by contaminants). Summa summarum.... it works in another way, so I am happy.

Your technology offers a beautiful way of winning alternative-energy, overlapping thermodynamic and "free-field" technologies.

Story:

I mentioned your WFC in a closed circle of my university professor colleagues, nobody accepted and believed....., "it can't work".....,

"it is against the theory..." was the reflexion.

I think, it shall be a very hard job to break up the the ignorance and resistance of "scientific" society, against the new technology (arab states, oil companies, energy industry, nuclear industry...e.c.t...).

But I like hard tasks, and therefore:

If you are planning middle-european activities, than hereby I am offering myself to be WFC distributor and education center for Austria and Hungary, Chechoslowakia, Jugoslavia, (also the neighbourhood small countries),  
to

propagate, sell and teach, developpe and applicate your technology. Enclosed: curriculum vitae.

I have some ideas for convenient broad-band marketing, and on the other hand in development (a simple computer controlled/optimized WFC-system, bio-medical, applications, e.t.c..).

Report on my labor experiments:

Input pulse-form:

3-100 ms. variable long, variable frequency  
(500-16000 Hz), positive square-wave pulse bursts.

Voltage intensifier:

12V to 600V (positive square wave bursts, about  
600V amplitude output)  
Copper wired permalloy transformer, with 20KHz  
bandwidth. Series, with the secondary coil, 1 KOhm  
resistor, to reduce currents.

Resonant chokers:

Copper wired ferrite inductivities, ca. 0.8H.  
due to ca. 10 nF Cell-capacity,  
with 1Kohm series resistors.

Diodes:

Si diodes, 1500V, max 1A.

Cell:

Plan-sandwich electrodes, outer negative, inner  
positive excitor 3" x 2" area, with 0,062" (1.6 mm)  
water-gap.

Result:

Power consumption for the whole system:  
3-5W (at 12VDC).  
ca. 0.5-1 cubic-centimeter gas in a minute,  
very little needle-flame!, 50% of the  
gas bulbs remains on the plates.....  
It seems to be, the geometrical and winding  
parameters of the voltage intensifier transformers  
may not be optimal, but your theory works.

Resumee:

For the same gas-quote, with the ionic technology requires about 10-12W energy. The relative effectivity is about 300% - at recent time.

LOOK →

Questions:

May I order a universal demo-WFC in the nearest future from yours WFC Inc.???

If it isn't possible, I need the winding parameters (at least the relations) of the voltage intensifier systems.

Thank you of yours attention.

Waiting, of Your answer, remaining with my best regards,

Yours cincerely,

T. Nagypal

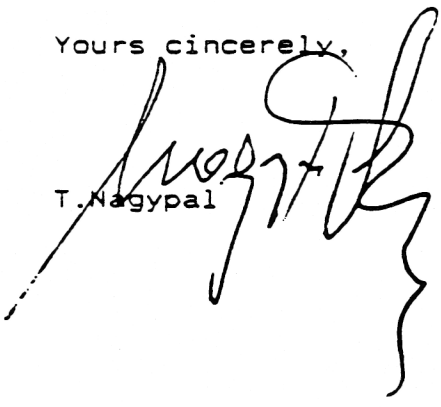

Dr. Tibor Nagypal  
Schulzlg 15/6  
A - 1210 - Wien  
Telefon: (0222) 306-483, 743-521-280  
Telefax: (0222) 743-521-289

C U R R I C U L U M V I T A E

Born, on 3. January 1942 in Budapest, Hungary.  
Married 1965, with Ildiko Benedek (1944).  
Three sons, Zsolt-1965, Tibor-1967,  
Laszlo-1977.

Studies-Diploms:

1960 Maturation, in Budapest. Egressy  
Realgymnasium.  
1965 MSc. Electronic Engrg., Budapest.  
1978 Studies on Hungarian Academy of Sciences.  
(all topics absolved with summa cum laude)

Topics:

Mathematik (Stochastic Processes),  
Computertechnology,  
Medical-Technology  
Biologie, Philosophy  
Neurophysiologie

1983 D.Sc.: Dr. Biol-Med. Univ. Szeged.

Nostrifikation in T. University. Vienna: Dr. Dipl. Ing.

Housing: in Budapest until 1983,  
in Vienna from 1983

Activity in Budapest:

1965: EMG. Inc. as Development Engr.  
1968: EMG. Head of Electronic Devl. Labor.  
1968-1969. Head of EEG-Laboron the Med. Uni-  
versity, Budapest.

1969-1983:

Organiser and later Chief of dept. of  
Computer-Center and Biophysics in  
National Institut of Neurosurgery and  
brain research b.t. Akademy of Sciences  
Research/Development/managing activity.  
Industrial Developments in sensorics,  
computer technology.  
Univ. Lecturer-activity, Techn. U. Budapest,  
UNESCO Postgraduation activity.  
Inventions, as: :Polarity-correlator 1968  
Languages: Hungarian, German, English, Russian.  
Coo-Author, 56 internat. Publications on  
medicine-technology, computertechnology.

Activity in Vienna:

1983: V.University Professor, on the Techn.University of Vienna, later as lecturer prof.

Topics:

Control processes in CNS.

International lecturer activity:

in München, Bern, Houston.

1989: Perceptionstechnology, T.U. Wien.

Research: Bio-Photonics-Technology, FFE,  
Image-recognition, Bio-Photonics:  
4 internatl. Publications recently.

1984 MTI GmbH. R&D-Cheef, Project: MIDAS System,  
Imager-quality-controll-system  
for Neusiedler AG.

1985 NORMA GmbH. Image processing consultant

1986 Optimed GmbH. Medimag System,

The first european VME-BV-System.

1987-1988 Stemmer GmbH & Co KG.: AT Imaging.

OS-9 VME-Videodisc System, 12-bit-

1.Msample/s. Data-aquisition system!

1988 KFJ-LAINZ . Radiation-quality Imaging-Project.

As Consultant Engineer and Scientist:

in interdiscipline-large-system

realisations. Specially in computer aided,

"intelligent"-sensorics, photonics.

1989 Firm (50% ownership), Compumedica GmbH.

with partners: Chemomedica GmbH, und Dr.W.

Kallinger, 1013 Wien, Wipplinger Str. 19.

1990 Institut for Neurophysics (private Institut).

1991 Firm: Perceptronic GmbH.50%-ownership, partner:

Ing. F.Jarosch, 1115 Wien, Am Kanal 27.(S.I.G.)

Vienna on 28, April, 1991

A large, stylized handwritten signature in black ink, likely belonging to the author of the document, is positioned in the lower-left quadrant of the page.

# Electrically Induced Explosions in Water

Gary L. Johnson  
Kansas State Univ.

1-10kV  
—| (—

## ABSTRACT

A 2  $\mu\text{F}$  capacitor was charged to voltages in the 1 - 10 kV range and discharged into a water column through a 38  $\mu\text{H}$  inductor. At voltages up to about 6 kV, the water acted as a relatively high resistance and the circuit decayed as an overdamped RLC circuit. Resistance decreased with time. When the resistance dropped below about 10  $\Omega$ , the water would explode if the capacitor still had sufficient energy. The loudness was distinctly greater than an equivalent amount of gunpowder.

During the explosion, resistance would drop still more, so the circuit would become underdamped and oscillatory. Remaining water droplets are cool to the touch, so there is no evidence that the water has boiled into steam, although that has to remain a possibility. A low impedance arc in air sometimes forms after the explosion so the explosion is not necessarily caused by an air arc.

## INTRODUCTION

For many years, a number of researchers have sought a completely new energy source, one freely and widely available. Tesla, Moray, and Bearden are among the better known of these searchers [1].

It is likely that some energy will have to be expended in order to tap into this source, perhaps in a manner similar to a heat pump. A heat pump is able to move several units of heat energy from the outdoors to air conditioned space for the cost of a single unit of electrical energy. The heat energy is readily and freely available, but requires an electrical input to move it to a desired location. The ratio of heat energy output to the electrical energy input is called the Coefficient Of Performance (COP) and is well over unity. So "over unity" machines are already widely used. But is there another source of energy in the ambient besides sensible heat? If there is, we would expect some experiments to yield more output energy than the known energy input. There would probably be nonlinear and threshold effects, which would help explain why the new source has not been previously identified. High voltages, high currents, and/or resonant phenomena may

be necessary. Experiments which may be operating in an "over unity" mode need to be carefully reported and then replicated by other researchers.

One such phenomenon which deserves a careful examination is electrically induced explosions in water. It has not been proven that the energy released by the explosion is greater than the electrical energy supplied (and doing so will be difficult), but there are certainly unexpected effects associated with the high voltage and high current operation. There is also an arc, which may be important in developing the new energy source [2].

A careful investigation of the phenomenon may yield new insight into basic electromagnetic theory, such as the longitudinal Ampere's force proposed by Graneau. It may illuminate a method of tapping into a new energy source, assuming the energy developed in the explosion is greater than the energy originally stored in the capacitor. And even if it can be fully explained by classical physics, it may still offer a technique for protecting the contacts of high voltage switches. With a water channel in series, the switch will close into a moderately high impedance, with minimal arcing. After a small time delay (allowing the switch to be fully closed), a plasma arc is established in the water, providing a low impedance path to the load.

## GRANEAU'S EXPERIMENTS

Peter Graneau, a physics professor at Northeastern University, and his associates, have performed several experiments with water-plasma explosions [3,4]. The basic circuit for all the experiments is shown in Fig. 1. The capacitor  $C$  is charged, and then discharged through an inductor  $L$  and a water column with effective resistance  $R_w$ . [3] describes a 0.5  $\mu\text{F}$  and a 2  $\mu\text{F}$  capacitor charged at voltages up to 10 kV, while [4] describes a 8  $\mu\text{F}$  capacitor charged at voltages up to 30 kV. The inductance was 876  $\mu\text{H}$  in [3] and 11.1  $\mu\text{H}$  in [4].

The discharge from a small voltage was silent, with no noticeable movement of the water. They call this type an electrolytic discharge. As either the voltage or the capacitance increased, an arc discharge would form, with audible noise. Arc formation seemed to depend on the total charge

ing through the water. A float above the arc would be pushed upward, but the impulse seemed to terminate with c. No followthrough push from expanding steam nor vapor escape from the water could be discerned.

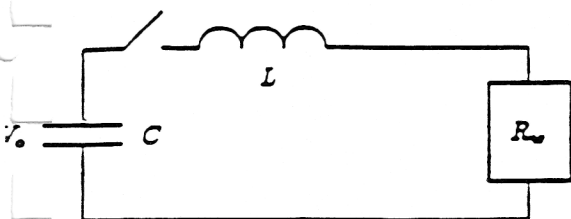

Figure 1: Water Arc Discharge Circuit

In two cases with the same stored energy, a 0.5  $\mu\text{C}$  capacitor charged to 6 kV and a 2  $\mu\text{C}$  capacitor charged to 12 kV, the second case resulted in an arc explosion while the first did not. In both cases, the heat dissipated in the arc was less than one calorie, in a container of about 120 ml of water. Their conclusion, based on measurement, calculation, and visual observation, was that the explosion was not based on thermal effects. They conclude, rather, that the explosion was due to longitudinal Ampere forces. This concept of a tension force in a single conductor due to current flow in the conductor is not taught in introductory electromagnetic theory courses, but Graneau makes a good case for such longitudinal forces in [5].

They discovered that tap water produced explosions about twice as strong as those in saturated saltwater. The explosions in distilled water were even stronger, except that it was difficult to initiate the arc in distilled water.

They calculated pressure in the chamber in the last test in which it was 27000 atm. Their comment was "This explains why the cartridge was split." They defined a figure of merit as the length of the explosion per unit action integral of the current pulse, and found that the figure of merit for their system was three times as high as the very best railgun performance. Railguns have better acceleration characteristics than chemical explosives, so water arcs have more "bang per buck" than any other explosive, save perhaps dynamite.

Water arcs are therefore interesting to study. At a minimum, they would indicate that Ampere's force law needs to have a longitudinal component. It is conceivable, however, that careful experimental studies will show that the total energy emitted from the explosion is greater than the electrical energy. This would certainly support the concept that the vacuum has a high energy density and that we might be able to extract some of this energy with a light equipment.

### HOME WORKSHOP EXPERIMENT

A well equipped high energy laboratory was available, so it was decided to replicate as much as possible of Graneau's arc experiments in a home workshop. The water column length and diameter would be varied and any instrumentation problems would be noted. No attempt would be

made to do any calorimetry measurements. These are far beyond the capability of this particular home workshop.

Two 0.5  $\mu\text{F}$ , and a 1  $\mu\text{F}$ , 25 kV, power factor correcting capacitors were purchased from the local junk yard. A 120:7200 volt potential transformer was purchased at an auction. Some 7.5 kV diodes were obtained from a surplus electronics catalog. No good high voltage switch was available, so a 100 A knife switch was borrowed from the electrical engineering department. The bakelite base would not withstand 10 kV, so the metal parts of the switch were mounted on a 6 inch PVC end cap, which worked quite well. The switch lever was extended about a foot with a section of PVC pipe to increase the clearance from the high potential parts.

The inductor consisted of 19 turns of 4 gauge wire on a piece of 6 inch PVC pipe, with inductance of 38  $\mu\text{H}$ . The exact value seems to be noncritical, since the primary purpose is to lower the resonant frequency to the point where the oscilloscope and other instrumentation can keep up with the oscillations.

Water contacts were made with two hollow brass structures about 1 cm in diameter that were obtained from a local lighting supplies store. These were approximately spherical where contact with the water was made. Heavy wire or copper tubing with bolted or soldered connections were used throughout to keep the circuit resistance to a minimum. The equivalent series resistance of the capacitors, the inductor, the switch, and the wiring was calculated to be 0.6  $\Omega$  from the oscillation obtained by discharging the capacitor into a short.

The oscilloscope used was a Phillips PM3350, rated at 50 MHz and 100 Megasamples per second, with the Phillips PM9355 current probe, rated at 7 ns rise time. Voltage was measured with a Keithley 602 Electrometer with a 30 kV probe. This high impedance probe was necessary to keep the measuring circuit from discharging the capacitors prematurely.

Ear plugs were essential. The reports were loud enough that operating in a typical campus building would be impossible during regular office hours.

### FALSE TRIGGERING

The contact arc at the switch and the current of several hundred amperes in the circuit emitted a strong electromagnetic pulse, adequate to cause false triggering in the scope. The scope would appear to collect data, but it was either before or after the event of interest. Filters were placed on both the probes and on the power lines, but made no difference. The radiation was entering the scope through its case rather than through the leads. Moving the scope further away helped, but not enough. A copper screen room was needed but none was available.

A poor man's screen room was built from two junk microwave ovens. These were identical units of a decade or more ago, when microwave ovens tended toward large and heavy, with a steel case. The insides were removed, and the front cut off from one and the rear cut off from the other. The two cases were then mated together with sheet metal screws. The final result looked like an unusually



deep microwave oven, complete with the door in working order. The scope would easily fit inside. A power line filter was added where the power cord entered the modified oven. The signal was brought in by a small 50  $\Omega$  coaxial cable through a small hole. The scope would be armed to collect data, the door closed, and then the knife switch closed. The door would then be opened and the trace examined. This technique eliminated the false triggering up to the limits of the experiment, approximately 10 kV and 1000 A.

## CURRENT PROBE

The Phillips PM9355 current probe is only rated to about 4 A peak, so some method of current division had to be used. The manufacturer suggested placing several identical wires in parallel, and measuring the current in one of the wires. This technique did not work because the probe would insert additional impedance into the wire being measured, causing the current to divide unequally. This effect is called the burden of the meter.

The solution was to put a 0.1  $\Omega$ , 10 W resistor in series with the water arc. A 50  $\Omega$  coaxial cable was connected across the resistor. The other end of the cable was terminated with a 50  $\Omega$  resistor inside the oven. Current through this resistor was then measured with the PM9355 probe. The 0.1  $\Omega$  resistor was placed inside an aluminum box to reduce the transient electric field effects. The burden of the probe was small compared with 50  $\Omega$  so this technique worked rather well.

## WATER COLUMN

Three different sizes of plastic tubing were obtained, with nominal inside dimensions of 1/8, 5/32, and 7/32 inches. These were cut in lengths of 1 and 2 cm. The tube was filled with saturated salt water or tap water and placed in a horizontal position between the two electrodes. Surface tension of the water was usually adequate to keep the water in place in an otherwise dry and clean piece of tubing. The electrodes were held in place by the stiffness of a few inches of 4 gauge copper wire. That is, the electrodes were free to move when an explosion occurred. For some tests, the electrodes were held to the tubing with large rubber bands. This would help keep the tubing in place for small water arcs, but seemed to have little difference on the results.

## RESULTS

Preliminary tests were performed with 1  $\mu$ F of capacitance and voltages up to 10 kV, on the shortest and thinnest piece of tubing. At voltages up to 7 or 8 kV, there would be little or no sound, but the water may be blown out of the tubing. At 9 kV there was a small "pop" part of the time. At 10 kV there was a larger pop, similar to a small firecracker. Tap water may have been slightly louder than salt water, but certainly not much. Low resistance arcs were hard to establish, so all the remainder of the tests were performed with 2  $\mu$ F of capacitance.

The circuit acts as an overdamped RLC circuit when the resistance of the water column is greater than about 3  $\Omega$ . The water resistance decreases with time and with the applied voltage, making it difficult to present specific values with broad application. Examples would be the 7/32 inch ID by 1 cm long tubing which had a resistance of 27  $\Omega$  at 6 kV and 17  $\Omega$  at 10 kV, at 10  $\mu$ s after switching, and the 5/32 inch by 1 cm long tubing which had a resistance of 55  $\Omega$  at 6 kV and 32  $\Omega$  at 10 kV, also 10  $\mu$ s after switching. Only if a low impedance arc forms will the resistance drop below 3  $\Omega$  and the current become oscillatory. This takes time to develop and will not occur consistently even for apparently identical conditions.

For example, compare two consecutive tries at 10 kV on the 1/8 inch ID by 2 cm long tubing. Both produced a loud bang, similar in loudness. In the first try, the current was 50 A at 5  $\mu$ s after switch closing, 80 A at 50  $\mu$ s, a peak of 130 A at 130  $\mu$ s, and went to zero at 153  $\mu$ s. In the second try, the current was 24 A at 5  $\mu$ s, 72 A at 50  $\mu$ s, and went to zero at 166  $\mu$ s. At 138  $\mu$ s, however, an arc was apparently initiated, so there was what appeared to be a half cycle of an underdamped wave between 138 and 166  $\mu$ s. The peak current of this half cycle was 540 A.

Longitudinal Ampere forces vary as the square of the current, so if the explosion is due to these forces we would expect a significant difference in loudness. Since little or no difference was noted in the explosion, there remains a question whether the longitudinal Ampere forces are even a major cause of the explosion.

Another observation was that of small bubbles forming in the tubing, with no arc and no noise. At 6 kV, a 7/32 inch by 1 cm piece of tubing would show a very small (less than 1 mm diameter) bubble. At 8 kV, the same tubing would show a bubble about 2 mm in diameter. The presence of a bubble will lower the arc inception voltage. That is, with the bubble in place, the next firing at 8 kV may be adequate to cause an arc with an oscillating waveform. Increasing the capacitance also lowers the arc inception voltage.

Loudness was found to be inversely proportional to the tubing area. The loudest reports were from the 1/8 inch ID tubing. Changing from salt water to tap water did not make nearly as great a difference.

Some numerical results are shown in Table 1. The voltage  $V$  is in kV, the maximum current is in A, and  $t$  is in  $\mu$ s after the switch is closed. The size is the nominal inside diameter in inches by the length in cm. The loudness of the bang varied from just noticeable to very loud as the voltage increased and the volume of water decreased.

Only the 1/8 inch ID tubing yielded waveforms that were partly oscillatory, and then only at 8 and 10 kV. Otherwise, the waveforms looked like a classic RC discharge curve, except that  $R$  is decreasing with time. This tends to flatten the curve, or even to let it rise to a peak sometime after the switching.

Another comparison on the longitudinal Ampere forces can be made from the 8 kV test of the 7/32  $\times$  1 and 5/32  $\times$  1 samples. The available energy was the same and the current waveforms were similar in appearance. The peak current for the 7/32  $\times$  1 was 272 A, with no noise, while the

Current for the 5/32x1 was 196 A, which produced a ...  
 The current density for the smaller tubing was  
 out 40 % greater than for the larger tubing, so perhaps  
current density is more important to a water explosion  
than the actual current.

2. Hathaway, George D., "Zero-Point Energy: A New Prime Mover? Energy Requirements for Energy Production & Propulsion from Vacuum Fluctuations", *Proceedings of the IECEC*, 1991.
3. Graneau, Peter and P. Neal Graneau, "Electrodynamic Explosions in Liquids", *Applied Physics Letters*, Vol. 46, No. 5, March 1, 1985, pp. 468-470.
4. Asevedo, Roy, Peter Graneau, and Charles Millet, "Powerful Water-Plasma Explosions", *Physics Letters A*, Vol. 117, No. 2, July 28, 1986, pp. 101-105.
5. Graneau, Peter, *Ampere-Neumann Electrodynamics of Metals*, Hadronic Press, Nonantum, Mass. 02195, 1985.

TABLE 1

Maximum Current and Time to Maximum

V	size	$i_{max}$	t	bang?
6	7/32x2	62	4	No
8	7/32x2	84	4	No
10	7/32x2	111	30	No
6	5/32x2	30	50	No
8	5/32x2	46	75	No
10	5/32x2	71	75	Yes ✓
6	1/8x2	26	100	No
8	1/8x2	45	140	Yes ✓
10	1/8x2	136	125	Yes ✓
10	1/8x2	420	140	Yes ✓
10	1/8x2	130	130	Yes ✓
10	1/8x2	540	150	Yes ✓
6	7/32x1	180	10	No
8	7/32x1	272	20	No
10	7/32x1	468	18	Yes ✓
6	5/32x1	111	30	No
8	5/32x1	196	30	Yes ✓
10	5/32x1	456	50	Yes ✓
6	1/8x1	91	45	Yes ✓
8	1/8x1	530	75	Yes ✓
10	1/8x1	940	45	Yes ✓

CONDITION WHEN CAPACITOR IS FULLY CHARGED - APPLYING THE HIGHEST VOLTAGE POTENTIAL OF OPPOSITE POLARITY OF VOLTAGE INTENSITY ACROSS SAID WATER-GAP ELECTRON CLUSTERING OCCURS WHEN SAID CAPACITOR IS IN THE FULLY-CHARGE STATE.

CONCLUSIONS

Electrically induced explosions in water are relatively easy to produce with a 2  $\mu$ F capacitor charged to 10 kV. Expanding steam does not seem to be the main cause. Similar explosions are obtained with significantly different peak currents, which raises questions about the longitudinal pressure forces being the primary cause. It is therefore conceivable that we are tapping a new energy source. More experiments need to be performed to demonstrate one way or the other. A better screen room, larger capacitors, and a better high voltage switch would be helpful. A variety of electrode and water channel configurations should be tested to separate out the effects of water arcs on water explosions. A calorimeter test would be interesting. A microphone pickup to electronically determine pressure would be useful. Of course, even if water explosions are tapping into a new energy source, this technique may not be the optimum way to extract this energy. But it could lead us toward a better understanding of this source.

REFERENCES

Johnson, Gary L., "Searchers for a New Energy Source", *IEEE Power Engineering Review*, Vol. 12, No. 1, January, 1992, pp. 20-23.

4.338

## POWERFUL WATER-PLASMA EXPLOSIONS

Roy AZEVEDO, Peter GRANEAU, Charles MILLET

*Center for Electromagnetics Research, Northeastern University, Boston, MA 02115, USA*

and

Neal GRANEAU

*Physics Department, King's College London, The Strand, London WC2R 2LS, UK*

Received 11 March 1986; accepted for publication 7 May 1986

The experiments described in this letter form a continuation of previously outlined research on electrodynamic explosions in liquids. Current pulse amplitudes have been increased from hundreds of ampere to 25 kA. The most powerful explosion so far observed imparted an impulse of 7 N s to a metallic projectile of 1.6 kg mass. The strengths of the impulses scaled proportionally to the electrodynamic action integral. For an arbitrarily chosen current pulse shape and magnitude, the plasma explosion in saltwater is much more powerful than the action of a railgun.

Underwater electric arcs are known to cause strong explosions. They have been used for metal forming and deep-sea pulse echo sounding. In a previous investigation [1] it was shown that, with pulse current amplitudes of a few hundred ampere, the explosions were driven by electrodynamic forces and not by high-pressure steam. If the electrodynamic mechanism is also operative at large currents, the explosive force should scale with the square of the current.

In a new series of experiments the scaling law was investigated with pulse current amplitudes up to 25 kA. A technique was developed for measuring the mechanical impulse given by the explosion to a metal weight. Of the two electrode configurations previously studied, that is the water cup and the straight-through channel, the latter was chosen for the higher current because it could be made strong without having to face serious materials and mechanical design problems.

Fig. 1 shows the dielectric cartridge with copper electrodes of the straight-through channel arrangement. The body of the cartridge was a block of glass-fiber reinforced epoxy, known as G-10.

Fiber-glass mats in the block resulted in a laminated structure which turned out to be a disadvantage. The  $\frac{1}{2}$ -inch-square copper bars were tightly fitted in a milled groove of the dielectric block and set flush with the upper surface of it. A  $\frac{1}{2}$ -inch-long butt-gap was left between the copper bars. This cavity was filled with the water in which the arc plasma was formed. Axial motion of the copper bars was prevented by four horizontal bolts passing through the bars and the dielectric block. A small dielectric plate (see fig. 2), of the same material as the cartridge body, was placed on top of the water-filled cavity. The metal weight to be accelerated by the explosion was put on top of the dielectric plate.

When the high-voltage capacitor bank C was discharged through the copper electrodes, as indicated on fig. 2, a bright arc plasma was formed in the water and completely filled the cavity W. This caused the explosion. Provided the cartridge was resting on a solid base, the metal weight would be thrown upward by the explosion. The vertical height through which it ascended was a measure of the impulse it received from the explosion. Fig.

0375-9601/86/S03.50 © Elsevier Science Publishers B.V.  
(North-Holland Physics Publishing Division)

101  
NOTICE: This material may be protected  
by copyright law (Title 17 U.S. Code)

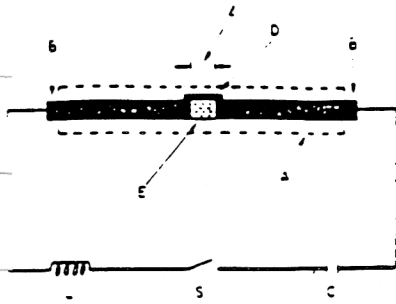

FIG. 4. Straightthrough channel experiment. A—transparent plastic board. B—0.5 × 0.5 in. copper rods. D—dielectric block. E—liquid conductor gap. L—induction coil. S—switch in air, and C—energy storage capacitor.

of convecting charges in vacuum, he found that convection currents did not obey Ampere's force law which had proved infallible in connection with metallic conduction. A similar dilemma has now arisen with the saltwater experiments. The ions in the electrolyte appear to behave like convecting charges in vacuum which almost certainly will experience Lorentz forces but not those predicted by Ampere's law. How Ampere forces may promote an explosion will be better understood from a second experiment.

Figure 4 shows the details of a straightthrough channel experiment. A half-inch-wide channel was milled in a transparent plastic board (A). Two copper bars of 0.5 × 0.5 in. cross section (B) were glued into the channel, leaving a butt-joint of length *l* between them. When the gap was 0.4 cm long and filled with liquid mercury, a 1000-A dc current was found to expel the liquid upward into the air. With longer gaps of, say, 10 cm length no liquid expulsion took place, but at about the 1000-A current level the liquid would separate from one or the other copper surface, interrupting the current with an arc. It was easy to expel salt water from a 1.7-m-long gap with a capacitor discharge that created a diffuse arc over the length of the gap. Yet electrolytic, arcless discharges through the salt water left the liquid still and undisturbed. When a small dielectric block (D) was placed over the water-filled gap, a 15-kV, 2-μF discharge would produce so strong an explosion that the block was fired at high speed to the laboratory ceiling and rebound to the floor.

In the mercury experiments the current distribution over the conductor cross section must have been uniform. In one of the experiments was the liquid temperature allowed

to exceed 100 °C. This was controlled by limiting the period of current flow. The return circuit was situated far enough away from the liquid gap so that it could exert no significant electrodynamic forces on the mercury. In the channel experiments the transverse pinch forces clearly act to contain the explosion rather than produce it. Hence we are left with longitudinal Ampere forces as the only possible explanation of liquid mercury expulsion from short gaps. Ampere repulsion between in-line current elements<sup>3</sup> is strong across the solid-liquid interfaces and can separate the two conducting media. The longitudinal repulsion forces also set up pressure in the middle of the gap. In short gaps this apparently became strong enough to lift the mercury out of the channel. Methods of computing longitudinal Ampere forces have been fully described elsewhere.<sup>3</sup> They would show that the force trying to separate liquid mercury from the copper interfaces at 1000 A is of the order of 0.5 N. This appears sufficient to explain the separation.

Finally we would like to mention arc-generated shock waves in toluene photographed by Wong and Forster.<sup>4</sup> A 0.5-cm-long cylindrical arc column of 5000 A was found to generate a bulging shock wave with its leading edge traveling radially outward halfway between parallel plate electrodes, just as expected if longitudinal Ampere forces were driving the shock. The shock wave was seen to collapse as soon as the arc was extinguished. Expanding gases generated in the arc column should have given rise to a cylindrical shock wave which persisted after the extinction of the arc.

Aspden<sup>5</sup> and Pappas<sup>6</sup> go further and suggest that the instabilities in fusion plasmas may also be the result of longitudinal electrodynamic forces. Water is much denser than low-pressure gas plasmas and therefore the question of whether Ampere forces will influence fusion technology remains unanswered.

This research was supported by Grant No. ECS-8023768 from the National Science Foundation.

<sup>1</sup>P. Graneau, *Nature* 295, 311 (1982); *J. Appl. Phys.* 53, 6648 (1982); *Phys. Lett. A* 97, 253 (1983); *J. Appl. Phys.* 55, 2598 (1984).

<sup>2</sup>E. F. Northrup, *Phys. Rev.* 24, 474 (1907).

<sup>3</sup>P. Graneau, *Nuovo Cimento B* 78, 213 (1983); *IEEE Trans. Magn.* MA-20, 444 (1984).

<sup>4</sup>F. P. Wong and E. O. Forster, *J. Electrostatics* 5, 157 (1978).

<sup>5</sup>H. Aspden, *IEEE Trans. Plasma Sci.* PS-5, 159 (1977).

<sup>6</sup>P. T. Pappas, *Nuovo Cimento B* 76, 189 (1983).

Obse  
by p<sup>+</sup>

In  
oscilla  
photoe  
um lam  
lective  
5461-2  
Hg I in  
have pr  
with w  
This le  
and 4f  
Å line  
4p/3d  
the 4f-3  
lasers.  
been p  
like an  
suggest  
techno  
in line  
may be  
wavele  
tude lo  
availab  
in this  
MW. S  
radiati  
rectly c  
F  
tal app  
gered  
cathod  
The di  
5-kA c  
ing las  
stream  
ture ar  
dischar  
ing las  
Fig. 1.  
The foc  
downs  
enhanc  
ultravi  
on the

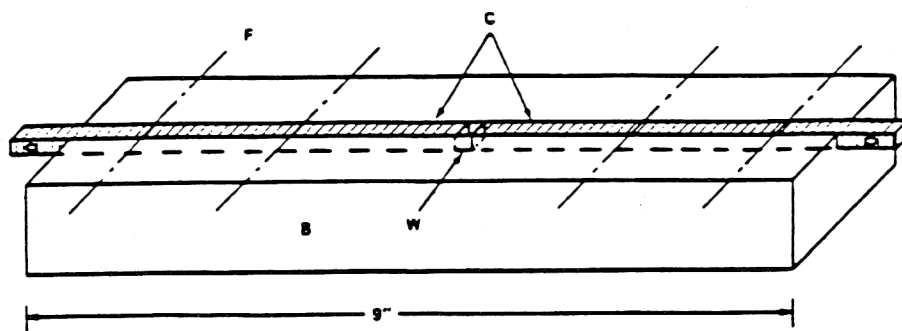

- B - GLASS-FIBER EXPOXY BLOCK
- C - 1/4 x 1/2" COPPER BARS
- W - 1/2"-CUBE WATER CAVITY
- F - RESTRAINING BOLTS

Fig. 1. Dielectric cartridge.

2 illustrates how this height was measured. The cartridge was placed on a sturdy porcelain stand-off insulator. A light wooden rod was attached to the metal weight. The rod passed through a hole in a stationary cross-bar. Two leaf springs were fixed

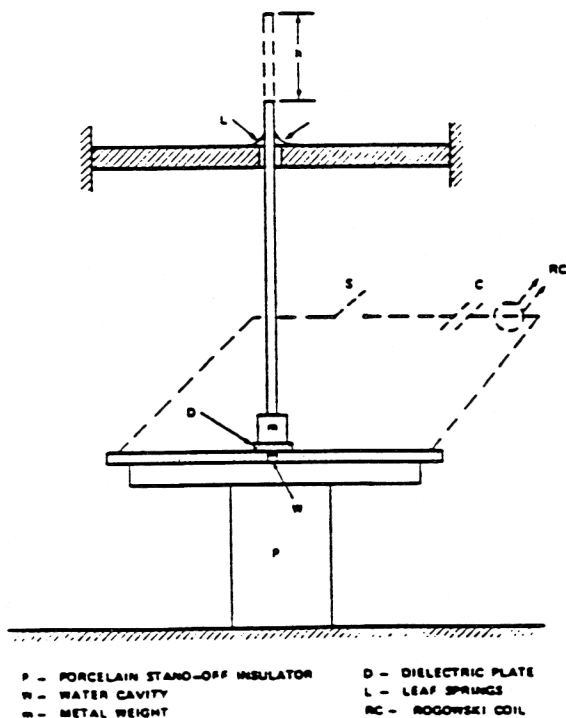

- P - PORCELAIN STAND-OFF INSULATOR
- W - WATER CAVITY
- M - METAL WEIGHT
- D - DIELECTRIC PLATE
- L - LEAF SPRINGS
- RC - ROGOWSKI COIL

Fig. 2. Impulse measuring stand.

to the top of the cross-bar. The springs permitted the upward motion of the rod, but gripped it firmly as soon as it tried to descend. The springs would actually hold the rod with the metal weight at the apex position for a subsequent measurement of  $h$ .

If the mass of the metal weight with rod and plate is  $m$ , the initial vertical velocity of the assembly is  $v_0$ , and the instantaneous lift force of the explosion is  $F$ , we have

$$\int_0^{\infty} F dt = mv_0 = m\sqrt{2gh} \tag{1}$$

where  $g$  is the acceleration due to gravity. Also shown on fig. 2 is the switch  $S$ , with which the previously charged capacitor bank was discharged, and a Rogowski coil  $RC$  for monitoring the current pulse.

Successive capacitor discharge shots at the same charging voltage, and therefore with nominally the same pulse current, did not lift the weight to the same height  $h$ . Time-constant variations recorded on the current oscillograms and the loud clap generated by the explosion left no doubt that a substantial fraction of the arc current was shunted from the water to surface flash-over in air. The air portion of the arc contributed little to the lift of the weight. This difficulty was largely overcome by machining a 1 mm deep, 1/4-half-inch square plunger on the underside of the dielectric plate  $D$

Volume  
of fig  
and d  
the ex  
to spr  
where  
The  
depend  
exper  
satura  
low-cu  
arc pl  
curren  
sion a  
to take  
curren  
from t  
expla  
water  
satur  
escalat  
difficu  
kV. A  
explos  
also re  
spite c  
finally  
exper  
this lec  
S was  
extern  
A n  
the car  
generat  
driven  
materia  
bend t  
damage  
comple  
pushed  
the lan  
leak ou  
and eve  
The da  
the fact  
explos  
the acc  
Assu  
trodyna

of fig. 2. This plunger fitted in the water cavity and displaced much of the air which had caused the external flash-over. It was also found helpful to spread a layer of grease on top of the cartridge where it touched the dielectric plate.

The strength of any explosion was found to depend on the salinity of the water. The early experiments [1] were performed with NaCl-saturated water. It was also discovered in these low-current experiments that, in the absence of an arc plasma, quite strong electrolytic convection currents through the saltwater created no explosion at all. Some electrolytic conduction is likely to take place right at the start of any discharge current pulse before arc formation. It will subtract from the strength of the explosion. This offers an explanation for the fact that explosions in tap-water were nearly twice as strong as those in saturated saltwater. Distilled water seemed to escalate the explosion even further, but it was difficult to break it down with voltages up to 30 kV. A reduction in the strength of underwater arc explosions due to electrolytic current flow was also reported by Gilchrist and Crossland [2]. In spite of the loss in explosive strength, it was finally decided to carry out the main series of experiments with a saturated salt solution because this led to immediate breakdown when the switch S was closed and thereby minimized the risk of external flash-over.

A number of the experimental shots damaged the cartridge assembly. At the very high pressure generated in the explosion cavity, water would be driven between the copper bars and the cartridge material. In some cases this caused the bars to bend upward. More serious was de-lamination damage of the cartridge body. On one occasion a complete layer of the laminated structure was pushed sideways out of the block. Sooner or later the laminations would part and permit water to leak out of the cavity. This made frequent repair and even replacement of the cartridge necessary. The damage suffered by the cartridge testified to the fact that a significant part of the energy of the explosion was given up to destruction rather than the acceleration of the projectile.

Assuming the explosion to be driven by electrodynamic forces, the mechanical impulse im-

parted to the projectile should obey an equation of the form

$$\int_0^{\infty} F dt = \frac{\mu_0}{4\pi} k \int_0^{\infty} i^2 dt, \quad (2)$$

where  $i$  is the instantaneous value of the pulse current,  $t$  is time,  $\mu_0$  the permeability of free space, and  $k$  is a dimensionless shape constant depending only on the layout of the circuit. If the force law governing the explosion is known,  $k$  may be calculated with the macroscopic current element analysis [3].

The underdamped discharge current pulse may be written

$$i = I_0 e^{-t/T} \sin \omega t, \quad (3)$$

where  $I_0$  is the initial current amplitude,  $T$  the damping time constant, and  $\omega = 2\pi f$  is the ringing frequency. In the previous letter [1] it has been shown that the action integral of (2) with eq. (3) is given by

$$\int_0^{\infty} i^2 dt = I_0^2 \left( T/4 - \frac{1/T}{(2/T)^2 + (2\omega)^2} \right) = I_0^2 T/4. \quad (4)$$

$I_0$  and  $T$  may be read off the discharge oscillograms obtained with the Rogowski coil RC of fig. 2. With eq. (2) the shape constant  $k$  may be expressed as

$$k = \frac{4\pi}{\mu_0} \int_0^{\infty} F dt \left( \int_0^{\infty} i^2 dt \right)^{-1}. \quad (5)$$

This is to say that  $k$  is an index, or figure of merit, of the strength of the explosion per unit action integral of the current pulse. For constant pulse shape and circuit layout, the figure of merit  $k$  should be constant. If for any given shot, in a series of identical shots, the measured value of  $k$  falls below this constant magnitude, it indicates that some inefficiency was at work. Inefficiencies of this nature do arise from air flashover, salinity differences, and water leaks.

Out of a series of 27 capacitor discharges, the results of the four most important shots are listed in table 1 and plotted on fig. 3. All four shots involved the full 8  $\mu$ F capacitance of the bank. The charging voltage  $V$  was increased in steps of 5

The circuit ringing frequency from the oscillogram with measured constant capacitance values and grams indicated  $k$ -values of 5765 to 6658. The index suggests to maximize the force of the current explosions.

To obtain shot 27, the copper bar was supplied in fig. 1. The short-circuit was obtained. The capacitance to the

$R_x = 2L/R$ . As before, the charge circuit. In the water arc, the arc, they have been of 65  $\mu$ s. Therefore, they be 255 meters and

$E = \frac{1}{2} CV^2$ . For shot 27, this energy should have

$\frac{R_s}{R_s + R_x}$ . The  $\frac{1}{2}$ -in. The late cal/cm<sup>2</sup>.

Table 1  
Experimental results.

Shot	C ( $\mu$ F)	V (kV)	$I_0$ (kA)	T ( $\mu$ s)	m (kg)	h (m)	$\int F dt$ (N s)	$I_0^2 T/4$ (A <sup>2</sup> s)	k	Remarks
20	8	15	12.7	65	0.977	0.123	1.52	2621	5799	old cartridge
25	8	20	16.9	65	0.977	0.508	3.08	4641	6637	new cartridge
26	8	25	21.2	65	0.977	0.950	4.21	7303	5765	new cartridge
27	8	30	25.4	65	1.597	0.975	6.98	10484	6658	new cartridge

kV from 15 to 30 kV. Shot 20 was the last reliable shot obtained with the first G-10 cartridge. Cumulative damage made subsequent shots with this cartridge unreliable. A new G-10 cartridge was then built, with the fiber-glass laminations vertical rather than horizontal. Shots 25 to 27 were the first three shots fired with the new cartridge. Shot

27 caused major water leaks, terminating the series of experiments.

As the nominal resistance of the water arcs was in the milliohm range, the initial current  $I_0$  was determined by the surge impedance of the discharge circuit, or

$$I_0 = V/\sqrt{L/C} \quad (6)$$

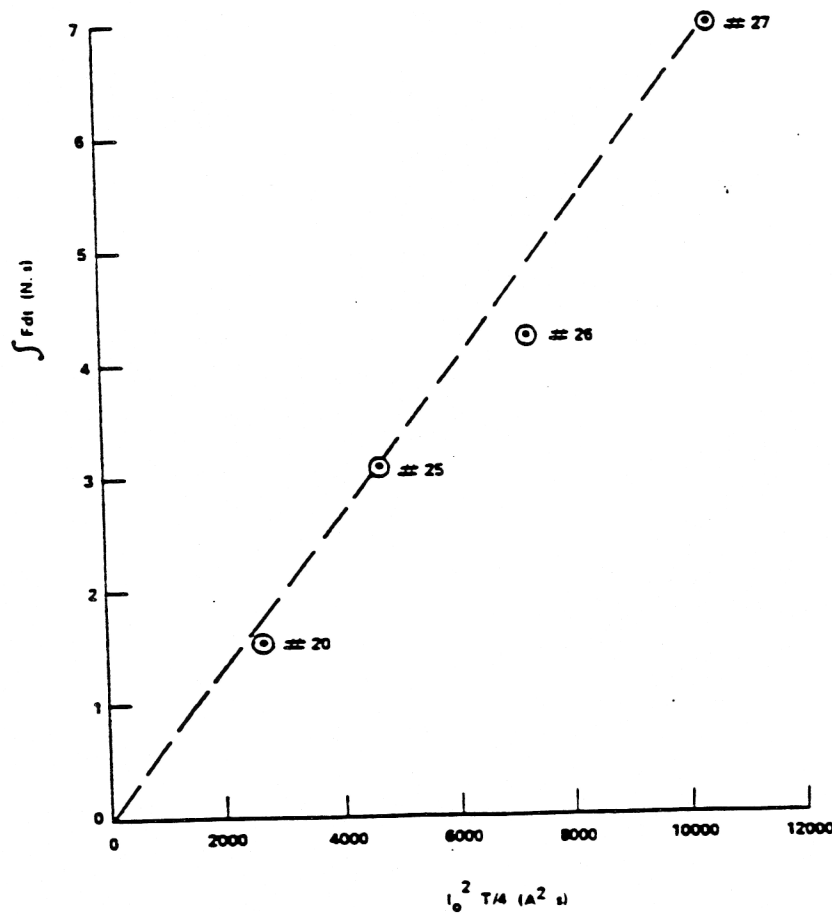

Fig. 3. Experimental results.

The circuit selfinductance  $L$  was derived from the ringing frequency recorded on the current pulse oscillograms.  $I_0$  calculated with eq. (6) agreed well with measurements of the Rogowski coil. The time constant  $T$  did not vary with  $V$  so long as the capacitance  $C$  was kept constant. The oscillograms indicated a time constant of 65  $\mu$ s. The  $k$ -values calculated for the four shots vary from 5765 to 6658. This nearly constant performance index suggested the apparatus was working close to maximum effectiveness as a projectile accelerator. It also provided evidence for the scaling of the force of the explosion with the action integral of the current pulse, as required for electrodynamic explosions.

To obtain an idea of the amount of energy that was supplied to the water arc of the most powerful shot 27, the cartridge was replaced by a solid copper bar of the length and cross section shown in fig. 1. When discharging 8  $\mu$ F at 30 kV through the short circuit, a time constant  $T_{sc} = 255 \mu$ s was obtained. If  $R_{sc}$  is the short-circuit resistance of the capacitor discharge circuit, this may be equated to

$$R_{sc} = 2L/T_{sc}. \quad (7)$$

As before,  $L = 11.1 \mu$ H, because the selfinductance depends only on the geometry of the discharge circuit which was not changed by the short circuit. In this way it was found that  $R_{sc} = 87 \text{ m}\Omega$ . If we assign an "effective" resistance  $R_a$  to the water arc, which must allow for the back emf in the arc, then the total resistance in shot 27 must have been  $R_a + R_{sc}$  which, with a time constant of 65  $\mu$ s, comes to 342  $\text{m}\Omega$ . Hence by the difference, the effective water resistance was found to be 255  $\text{m}\Omega$ . The total energy stored in the capacitors and then dissipated in the circuit was

$$E = \frac{1}{2} CV^2. \quad (8)$$

For shot 27 this came to 3600 J. The fraction of this energy consumed in the water arc therefore should have been

$$\frac{R_a}{R_a + R_{sc}} E = 2684 \text{ J} = 642 \text{ cal.}$$

The  $\frac{1}{2}$ -inch-cube water volume is equal to 2  $\text{cm}^3$ . The latent heat of evaporation of water is 529 cal/ $\text{cm}^3$ . Hence the energy deposited in the water

was insufficient to evaporate it all, let alone superheat it to the required pressure.

The pressure accelerating the projectile may be estimated with eq. (2) and (4). Let us define an average acceleration force  $F_{av}$  for electrodynamic explosions as follows

$$\int_0^\infty F dt = \frac{\mu_0}{4\pi} \frac{kI_0^2 T}{4} = \frac{F_{av} T}{4}. \quad (9)$$

Therefore

$$F_{av} = (\mu_0/4\pi) kI_0^2. \quad (10)$$

In the case of shot 27 this average force was found to be no less than

$$F_{av} = 4.3 \times 10^5 \text{ N.}$$

When converting this figure to a pressure on the underside of the projectile it comes to 27000 atm. This explains why the cartridge was split.

Regardless of the force law governing the explosion [3,4], the water plasma cartridge may be treated as an electromagnetic accelerator with a high performance index  $k$ . Another - and perhaps the best known - electromagnetic accelerator is the railgun. Deis et al. [5] described experiments with one of the most powerful railguns so far built. It obeys eq. (5) and was found to have a performance index of  $k = 5.85$ . Coaxial accelerators [6] are known to be more effective than railguns. The induction accelerator is a special form of coaxial accelerator. It was first described by Bondaletov [7] who achieved with it a record performance index of  $k = 2000$ . The series of water plasma explosions described in this letter betters this by a factor of three.

## References

- [1] P. Graneau and P.N. Graneau. Appl. Phys. Lett. 46 (1985) 470.
- [2] I. Gilchrist and B. Crossland. I.E.E. Conf. Publ. No. 38 (London, December 1967) p. 92.
- [3] P. Graneau. Ampère-Neumann electrodynamics of metals (Hadronic Press, Nonantum, 1985).
- [4] H. Aspden. Phys. Lett. A 111 (1986) 22.
- [5] D.W. Deis, D.W. Schertbarth and G.L. Ferrentino. IEEE Trans. Magn. MAG-20 (1984) 245.
- [6] H. Kolm and P. Mongeau. IEEE Trans. Magn. MAG-20 (1984) 227.
- [7] V.N. Bondaletov. Sov. Phys. Technol. 12 (1967) No. 2.





INSTITIÚID TEICNEOLAÍOCHTA BHAILE ÁTHA CLIATH  
DUBLIN INSTITUTE OF TECHNOLOGY

14 Upper Mount Street, Dublin 2.

Telephone: 01 - 611133.

Fax: 01 - 762608.

INDUSTRIAL LIAISON OFFICE

Industrial Liaison Officer: Rea O'Neill, M.A., M.Sc., M.Inst.P.

SIMPLE EXPLANATION OF  
MEYER FUEL CELL TECHNOLOGY

The electrolysis process is not dependent on energy. From Arrhenius theory, molecules in solution dissociate into ions and the ions are collected at the electrode. No energy is required for ionic dissociation and electrolysis processes are so efficient that they are used to measure current e.g. silver coulometer.

When we apply this to the dissociation with water, the key requirement to produce 1.008 gm of hydrogen is that 1 Faraday of electricity flows\*. (1 Faraday equals 96,494 coulombs).

If we assume that this is produced by passing 2 amps of current for 96,494 secs. at  $\frac{1}{2}$  volt, then the energy needed is  $\frac{1}{2} \times 2 \times 96,494$  joules or 96,494 joules i.e. 96.494 KJ of energy.

The same mole of  $H_2$  is capable of releasing 285 KJ of energy on combustion with oxygen.

The process of producing  $H_2$  from water usually requires an electrolyte to produce it in quantities.

It suffers from polarisation at the electrodes with hydrogen collecting there. A number of methods are known for improving the efficiency of the process. In theory the process can be made energy efficient without a breach of any of the laws of thermodynamics.

Meyer has obviously discovered some method of collecting the hydrogen different from the traditional methods.

\* *From Faraday's Laws of Electrolysis*

The Dublin Institute of Technology was established by the Dublin Institute of Technology Act 1992 and is constituted from

College of Technology, Bolton Street.  
College of Technology, Kevin Street.

College of Catering, Cathal Brugha Street.  
College of Marketing & Design, Mountjoy Square

College of Commerce & Finance  
College of Music, St. John's Road



INSTITIÚID TEICNEOLAÍOCHTA BHAILE ÁTHA CLIATH  
DUBLIN INSTITUTE OF TECHNOLOGY

14 Upper Mount Street, Dublin 2.

Telephone: 01 - 611133.

Fax: 01 - 762608.

INDUSTRIAL LIAISON OFFICE

Industrial Liaison Officer: Rea O'Neill, M.A., M.Sc., M.Inst. P.

REPORT ON VISIT TO STAN MEYER

I visited Columbus Ohio to meet Stan Meyer and discuss Water Fuel Cell Technology from 28th July to 31st July 1993. I was accompanied by Noel Whitney of Quantum Leap and Michael Carberry, Chief Engineer of Avonmore Plc.

During the course of our stay most of our time was spent discussing the underlying principles behind the technology and the details of the electronics circuits etc. On the second day Meyer demonstrated a version of his water fuel cell technology which was built in 1982. This demonstration clearly indicated to me that Meyer has developed a novel process for producing hydrogen and oxygen together. This process does not utilise the large currents needed for normal electrolysis.

Since my return to Ireland I have studied the literature and compared this with the data supplied by Meyer. I have formed the view that Meyer has developed a novel form of electrolysis for water and that this form of electrolysis has the potential to make available more heat energy than the energy input needed to stimulate the process. I have explained this process on the accompanying pages.

In all the time I had contact with Meyer, I formed a very positive view of his sincerity and his enthusiasm. From the literature supplied, the patents and equipment shown to us it is evident that Meyer has concentrated his development on producing this water fuel cell in a form immediately suitable for retrofitting to the everyday motor vehicle. To complete this development he has to develop his electronics further to produce an integrated chip and this will take some further months.

I am convinced that the technology demonstrated is a novel and exciting technology and will provide an alternative fuel for use in motor vehicles in the not too distant future. It is difficult at this stage to assess whether its performance as a simple burner will exceed the performance of existing technology from heat pumps etc. The substantial gain to be made if this proves to be the case, however, would justify significant investment to move to the proof of concept stage.

Signed:

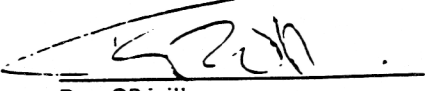
  
Rea O'Neill

Industrial Liaison Officer

The Dublin Institute of Technology was established by the Dublin Institute of Technology Act 1992 and is constituted from:

College of Technology, Bolton Street:  
College of Technology, Kevin Street:

College of Catering, Cathal Brugha Street.  
College of Marketing & Design, Mountjoy Square.

College of Commerce, Rathmines.  
College of Music, Adelaide Road.

## EXPLANATION OF MEYER FUEL CELL

In ordinary water a small amount of the water dissociates to hydrogen and hydroxyl ions. These ions are immediately hydrated. The amount dissociating depends on the purity of the water and in very pure water is equal to 1 part in 10 million. Normally ordinary water is described as non-conducting. The process has never been fully explained. Hydrogen and hydroxyl ions are constantly being created and then decaying back to water, but there is always a balance between the numbers ionised and the numbers in solution. (See Appendix I for details of the ionic process involved).

Under normal electrolysis these ions can be swept to electrodes and neutralised with the opposite charge. Hydrogen and Oxygen can be produced. With conventional circuits however, the energy used in collecting the hydrogen is greater than the energy that is available from the hydrogen. Meyer has utilised a novel electronic circuit which produces high voltages but prevents currents from flowing. This circuit is similar to a classical forced oscillation circuit where charge  $q$  can go to infinity. (See Appendix II).

The power to this circuit is coming from an alternator which is across a stainless steel capacitor with water between its plates. The dielectric water itself provides the charge to charge up the capacitor and create the high voltage. This charge comes from the hydrogen and hydroxyl ions. The more charge that flows the more the voltage builds up and the more ions are pulled out of solution. The circuit has a high frequency of the order of five kilohertz superimposed through the windings of the field coils. In addition the circuit is half-wave rectified to allow the capacitor to discharge.

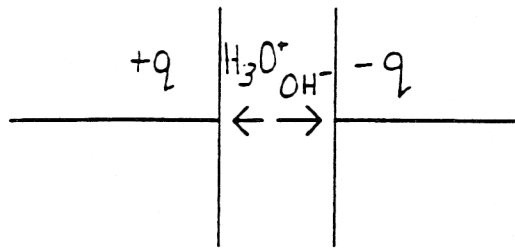

Fig.1

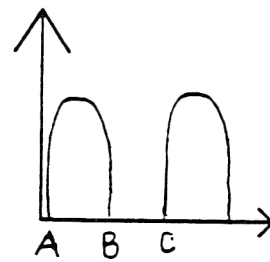
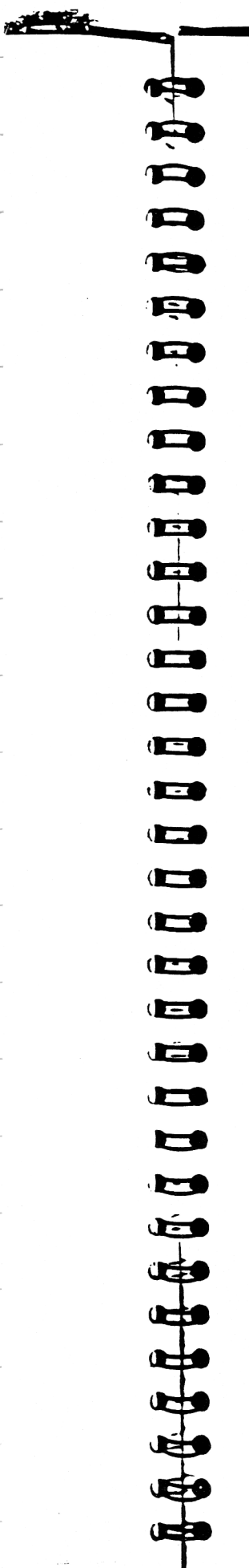

Fig.2.

On the charging up side the ions are pulled out of the dielectric and moved towards the metal electrodes. On the discharging side they may go back into solution. The circuit succeeds in increasing briefly the number of ions which are out of solution.

A portion of these ions are able to form hydrogen and oxygen by normal electrolysis type processes. The hydrogen and oxygen bubble to the surface. The circuit is novel in that it is a form of electrolysis but there is no need for any net current to flow. While the voltage applied is zero the ionised charges are able to recombine without flowing around the circuit and using energy.

Theoretically there is no reason why the process cannot be totally efficient in producing hydrogen and oxygen. The efficiency depends on the tuning frequency of the LC circuit and having this balanced with the mobility of the ions and the spacing between the plates. There may also be a need to allow a definite relaxation time after



each pulse, to increase the period B to C in which the ionised charges may recombine and hydrogen and oxygen may be collected.

The process does not defy the laws of thermodynamics in that the energy comes from the energy of dissociation of the molecules. A portion of the molecules are dissociating and associating automatically all the time. In the normal course of events this does not change the energy of the water. This process interrupts this cycle and allows a portion to form water in the stable state of  $H_2$  and  $O_2$ .

The process is not dissimilar to the vapourisation of water which takes place naturally. The water forms clouds, then rain. Rivers flow and energy is extracted from the rivers. The difference is that it is possible to carry out the cycle under laboratory type conditions or industrial type conditions and extract the energy in the form of hydrogen.

By developing a process to utilise the hydrogen ions directly on formation, a great deal more energy will be available and this is Meyer's intention in terms of adaption of his fuel cell for an ordinary car. In addition he utilises laser light to stimulate the transfer between energy levels and increase the efficiency of the process.

This process would equally explain the explosions in water performed in the University of Kansas which have been recorded in the literature. Deuterium present in the water will be selected out during the reaction and the water remaining in the condenser will become deuterium rich which will inhibit the process.

In the process gases absorbed in water are preferentially desorbed. These amount to 3 per cent approximately of water by weight. It is not clear if they play any significant part in the process. In addition impurities in the water are taken out of the solution.

On the basis of the theory proposed, the process could continue indefinitely, the energy effectively coming from the zero point energy of vibration of the atoms in the molecule. This is probably assisted by infra red radiation from the surroundings so that the whole device will act as an efficient heat pump. The deuterium vibrations will be similar in frequency to the hydrogen vibrations. Resonance affects between the two vibrations may also contribute to the process. If this is a serious contributor to the process then the water produced from the hydrogen and oxygen will be less likely to produce further energy as the deuterium will have largely been selected out in the total process. There is no reason to believe this is the case and in any event the balance will be restored by nature mixing the water formed with normal water vapour.

**Where does the energy come from?**

Effectively the water molecule is marginally unstable in water solution and is constantly acting as a 'radioactive' molecule tossing out  $H^+$  and  $OH^-$  ions. The energy of the process comes from the formation energy of these ions.

## APPENDIX I

### BORN-HABER CYCLE FOR MEYER PROCESS

*All energies in Kilo Joules per mol.*

H -OH	Dissociation Energy	+ 494
H <sup>+</sup>	Ionization	+ 1310
Hydration of H <sup>+</sup> to form H <sub>3</sub> O <sup>+</sup>		- 1075
Election Affinity of OH (Assumed Affinity is between that of O and Cl)		- 223
		<hr/>
Total =		506

In normal water a portion of the ions are dissociated. For pure water this is one in 10 million. Initially H<sup>+</sup> and OH<sup>-</sup> are formed but are immediately hydrated to H<sub>3</sub>O<sup>+</sup> and OH<sup>-</sup>. From the above for the H<sub>3</sub>O<sup>+</sup> and OH<sup>-</sup> ions the energy of formation is 506KJ/mole.

**This process occurs naturally without any electrical input etc. If these ions are removed more are produced by the water.**

This process can be explained by quantum mechanics. The atoms in the molecule will have a 'zero point energy' of vibration and therefore there is a finite chance of dissociation. With high electric fields this chance would be greatly increased. (See Pages 520 and 521 of Fundamental Atomic Physics, Tomlin). The release will also be affected by the presence of other ions which again affect the potential.

Once released the full energy of dissociation will be available as energy.

The hydronium ions and the hydroxyl ions formed by this process may form gases by the following process:

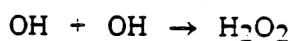
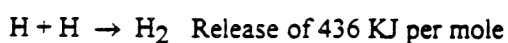
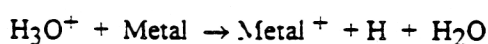

#### Overall Reaction

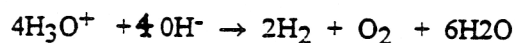

As it takes 2 H atoms to form  $\text{H}_2$  only half of the 436 KJ will be involved in the process.

As it takes 2OH to produce  $\text{H}_2\text{O}_2$  only half of the energy of this reaction will be involved in the process.

For the formation of  $\text{O}_2$  it will take 4 OH radicals and therefore one quarter of the energy will apply in this case.



This allows us to construct the following energy level diagram:

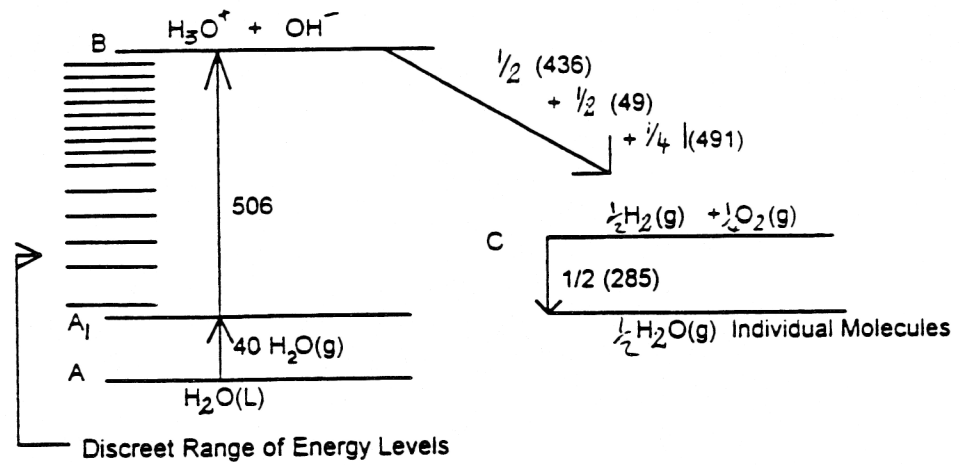

If we start at point B on the cycle it is easy to explain how we can release nett energy from the process. As level B is depopulated it will automatically be filled from the lower levels. The interaction between these levels will be stimulated by infra red radiation so will be stimulated in most environments. In normal circumstances the population of the highest level will be much lower than the lowest energy level (zero point level). This should be altered somewhat by the high potential electric field applied to the condenser. This will alter the barrier to penetration as in the figure below and increase penetration.

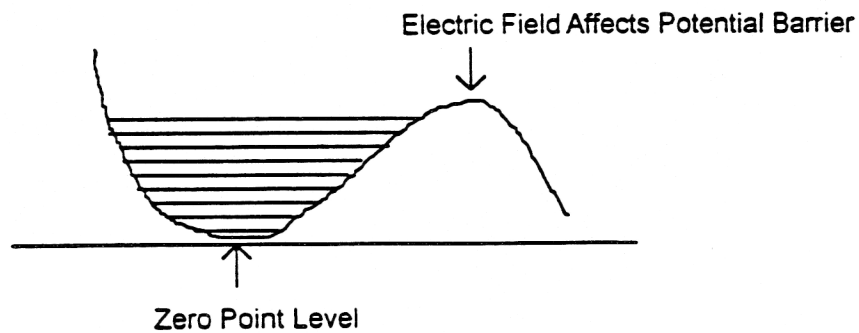

There will be a limit to power from a given volume of water between the plates at any one time as obviously all atoms cannot be raised to the higher levels without pumping in energy. The application of a high electric field in itself is an efficient way of increasing the number of ions released in the process especially as the electrical field is stimulated by the ions themselves.

The original energy available from the naturally occurring process of formation of  $H^+$  &  $OH^-$  ions is 494 (Bond Formation) plus 1310 (Ionization Potential) - 223 (Electron Affinity of OH) = 1511 (All energies in KJ per mole).

By this process we are only tapping into a fraction of the energy available from splitting the molecule. By utilising  $H^+$  and  $OH^-$  immediately on formation much greater energy yields can be obtained.

However, to achieve that will be more difficult as the lifetime of the excited state involved will depend on the energy gap between that state and zero energy level. The lifetime is estimated at  $2.5 \times 10^{-17}$  seconds, whereas the  $H_3O^+$  and  $OH^-$  stage seems to be a semi stable state in water solution because of the hydration by water (Hydrogen Bonding).

Comparing (17.32) and (17.33), we find

$$H_{n+2} = \zeta H_{n+1} - (n+1)H_n$$

or

$$H_{n+1} = \zeta H_n - nH_{n-1} \quad (17.34)$$

which is a useful recurrence formulae. The wave functions (17.29) are orthogonal, and can be normalized by using the result

$$\int_{-\infty}^{+\infty} [H_n(\zeta)]^2 e^{-\zeta^2} d\zeta = (2\pi)^{\frac{1}{2}} n! \quad (17.35)$$

$$\begin{aligned} \text{for we have } \int_{-\infty}^{+\infty} [u_n(x)]^2 dx &= C_n^2 \beta^{\frac{1}{2}} \int_{-\infty}^{+\infty} [H_n(\zeta)]^2 e^{-\zeta^2} d\zeta \\ &= C_n^2 (2\pi\beta)^{\frac{1}{2}} n! \end{aligned}$$

which is equal to unity if  $C_n = (1/n!(2\pi\beta)^{\frac{1}{2}})^{\frac{1}{2}}$ . Hence the normalized wave functions for the one-dimensional harmonic oscillator are

$$u_n(x) = \left[ \frac{1}{n!(2\pi\beta)^{\frac{1}{2}}} \right]^{\frac{1}{2}} H_n(\beta^{\frac{1}{2}}x) e^{-\frac{1}{2}\beta x^2} \quad (17.36)$$

where  $\beta = 4\pi(MK)^{\frac{1}{2}}/\hbar = 8\pi^2 M\nu_0/\hbar$ .

### 17.5 Anharmonic vibrations

The vibrations of real molecules are not necessarily of the simple harmonic kind, though the approximation is often very close when the amplitudes are small. As soon as the potential energy of the system departs from the parabolic form, i.e. from dependence on the square of the displacement, the motion becomes anharmonic.

In a diatomic molecule in its ground state of electronic motion, the dependence of potential energy on the interatomic separation is of the form shown in fig. 17.6. The curve approaches a horizontal asymptote at large separations  $x$ , since in the limit  $x \rightarrow \infty$  it must represent the dissociated state of the system. For comparison, a parabolic potential is also shown with the vibrational energy levels characteristic of the harmonic oscillator indicated by equally spaced horizontal lines. The points where one of these lines intersects the potential curve define the turning points (maximum and minimum displacements) of a classical oscillator of the same total energy. Wave mechanics shows that there is a finite probability of displacements beyond the classical limits, a result which is closely related to the barrier penetration effects discussed in section 13.10.

In the case of small vibrational quantum numbers, there is fairly close agreement between the actual energy levels and those of the harmonic

oscillator, because the actual potential curve departs only slightly from the parabolic shape. As the excitation increases, however, the restoring force becomes weaker than that corresponding to the same parabolic potential, with the result that the energy levels are depressed relative to the harmonic values  $(n + \frac{1}{2})h\nu_0$ , and converge towards a continuum as the dissociation asymptote is approached. Energy levels above the asymptote correspond to the motion of two free atoms, and must form a true continuum. The

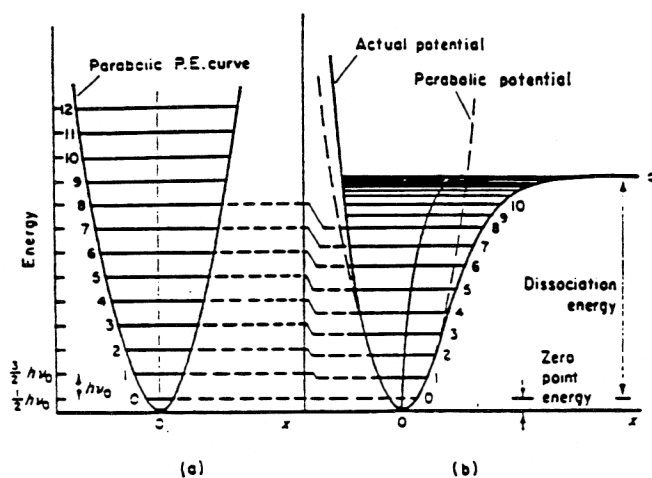

Fig. 17.6 Vibrational energy levels for (a) a harmonic linear oscillator, for which the potential energy is parabolic, and (b) the type of anharmonicity occurring in the vibrations of an actual diatomic molecule. In (b) the potential energy departs from the nearest parabolic approximation except at small amplitudes (small quantum number)

dissociation energy of the molecule is given by the difference between the asymptote and the lowest energy level ( $n = 0$ ). This does not coincide with the minimum point on the potential curve on account of the zero point  $\frac{1}{2}h\nu_0$ . An alternative graphical illustration of the effect of anharmonicity on the energy levels is given in fig. 17.7.

In addition to destroying the equal spacing of energy levels, the anharmonicity has an important effect on the selection rule governing transitions between the quantized vibrational states. If we consider a harmonic classical oscillator in which the oscillatory coordinate  $x$  is the distance between a pair of oppositely charged bodies, we find that electromagnetic radiation is emitted, having just the fundamental frequency  $\nu_0$  of the oscillation. According to the correspondence principle, therefore, only

## APPENDIX II

### ELECTRICAL CURRENT

Similar to Forced Oscillation circuit described in text and designed to maximise.

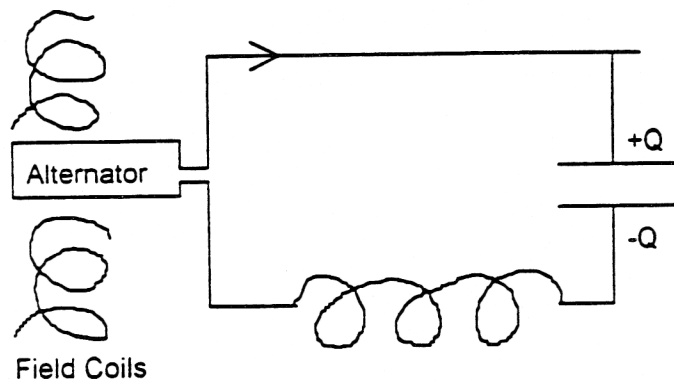

#### APPROXIMATE SPECIFICATION

Field Coils	-	5 volts, 2 amps
Alternator	-	Driven by 2 Kilowatt Motor
Inductance	-	Unknown
Condenser	-	Formed from 8 - 10 half inch stainless steel tubes surrounded by three quarter inch stainless steel tubes wired in parallel

electrical energy into heat energy at each oscillation. It may be shown that, in the presence of resistance  $R$ , equation (15.2) transforms to

$$L \frac{d^2Q}{dt^2} + R \frac{dQ}{dt} + \frac{Q}{C} = 0, \quad \dots \quad (15.7)$$

and (15.4) becomes

$$T = \frac{2\pi}{\sqrt{1/LC - R^2/4L^2}}, \quad \dots \quad (15.8)$$

so the time of oscillation is increased in the presence of resistance. It will be observed that the frequency of the oscillation depends on the *product*  $LC$  and the *ratio*  $R/L$  and not on the individual values of these three quantities.

### 3. Forced Oscillations.

A circuit containing inductance and capacity alone has a natural frequency of oscillation given by  $n = 1/(2\pi\sqrt{LC})$ , according to the considerations of the preceding paragraph. Consequently it corresponds exactly to any other vibrating system such as an organ pipe or a stretched string. We have seen in Part IV, Chap. IV, how any such system may be forced to oscillate if excited by some external oscillating supply, but that the magnitude of the excited oscillations is generally small except at resonance. Precisely similar relations are found if an alternating E.M.F., such as is provided by a dynamo without a commutator, is applied to a circuit containing inductance and capacity. At any time  $t$ , let the applied E.M.F. be  $E = E_0 \sin pt$ , where  $E_0$  is the maximum amplitude of the E.M.F. and its period is  $2\pi/p$ . The total E.M.F. is now  $Q/C + E_0 \sin pt$ , and equation (15.2) becomes

$$L \frac{d^2Q}{dt^2} + \frac{Q}{C} = -E_0 \sin pt. \quad \dots \quad (15.9)$$

The forced oscillations which are set up will clearly be of the same frequency as the forcing supply and of simple harmonic form. The solution of (15.9) corresponding to the forced oscillations is therefore of the form

$$Q = A \sin pt + B \cos pt, \quad \dots \quad (15.10)$$

where  $A$  and  $B$  are constants.

Just as in our treatment of the S.H. equation in Part I, p. 23, to determine  $A$  and  $B$  we differentiate (15.10) and substitute in (15.9). Hence we obtain

$$\frac{dQ}{dt} = pA \cos pt - pB \sin pt$$

and 
$$\frac{d^2Q}{dt^2} = -p^2(A \sin pt + B \cos pt). \quad \dots \quad (15.11)$$

Substituting from (15.10) and (15.11) in (15.9) we obtain

$$-p^2L(A \sin pt + B \cos pt) + \frac{1}{C}(A \sin pt + B \cos pt) = -E_0 \sin pt. \quad (15.12)$$

When  $t = 0$ ,  $\sin pt = 0$  and  $\cos pt = 1$ ; hence, substituting this condition in (15.12),  $(-p^2L + 1/C)B = 0$ , and therefore  $B = 0$  (if we assume that  $-p^2L + 1/C$  is not zero). When  $pt = \pi/2$ ,  $\sin pt = 1$  and  $\cos pt = 0$ ; substituting this condition in (15.12),

$$-p^2LA + \frac{A}{C} = -E_0.$$

or

$$A = -\frac{E_0}{(1/C - p^2L)} \dots \dots \dots (15.13)$$

and equation (15.10) becomes

$$Q = -\frac{E_0}{(1/C - p^2L)} \sin pt. \dots \dots \dots (15.14)$$

The forced oscillation of  $Q$  is therefore in phase with the forcing oscillation, if  $p^2L$  is greater than  $1/C$ . If  $Lp = 1/Cp$  or  $p = 1/\sqrt{LC}$ , that is, if the forced oscillations are of the same frequency as the natural period of the circuit, according to (15.14) the charge  $Q$  becomes infinite. With a circuit of zero resistance, if radiated energy is neglected (see Chap. XVI), this situation would occur. In practice, however, the resistance which is actually present acts as a damping factor and keeps the charge (and current) finite although large.

We next consider the case of a circuit containing inductance and resistance. The electromotive force equation becomes

$$L \frac{dI}{dt} + RI = E_0 \sin pt, \dots \dots \dots (15.15)$$

and we solve this by precisely the same method as we have already used in this section. Assuming  $I = A \sin pt + B \cos pt$ , we find

$$A = \frac{RE_0}{L^2p^2 + R^2}, \dots \dots \dots (15.16)$$

and

$$B = \frac{-LpE_0}{L^2p^2 + R^2}.$$

Hence

$$I = \frac{E_0}{L^2p^2 + R^2} (R \sin pt - Lp \cos pt). \quad (15.17)$$

If we construct a triangle as in fig. 3 with  $\cos \theta = R/\sqrt{L^2p^2 + R^2}$ ,

PERKINS TECHNOLOGY LTD  
MEETING WITH  
ADMIRAL SIR ANTHONY GRIFFIN  
1100 THURSDAY 28th FEBRUARY 1993

INTRODUCTION

1. The purpose of this meeting is to decide whether or not Perkins wishes to proceed with the TACO agreement in the light of Stan Meyer's proposed contract.

FACTORS AGAINST

2. The proposed contract calls for a deposit of \$125k leading to a total for TACO Phase 1 (plus part TACO Phase 2) of \$147.374k and contains a 'no redress' clause in the event of WFC failure.

3. On none of the 3 occasions, October 1990, August 1992 and October 1992, when UK experts visited Ohio, was there a practical demonstration of a running internal combustion engine fuelled by water in accordance with WFC technology.

4. A substantial number of UK scientists and engineers regard WFC technology as in breach of the first and second laws of thermodynamics.

FACTORS IN FAVOUR

5. Repeated practical demonstrations of Meyer's equipment in support of his original patent in 1980. Electrolysis was clearly not involved, consequently dissociation was being achieved by some unfamiliar process.

6. Meyer's readiness to commit himself and his technology to a major public demonstration in the UK, the first to be held outside the US.

7. Numerous US companies, including for example Pratt & Whitney, are known to have entered into similar forms of contract amounting, in August 1992, to over \$200m worth of deposits.

8. The US Air Force, (at the Wright Patterson Airforce Base near Columbus, Ohio) is now negotiating a jet conversion contract with Meyer.

9. Meyer reports that US pollution controls on US diesel engines are proving over costly. Apparently several US diesel manufacturers are now looking seriously at WFC.

10. German and Dutch companies are now negotiating contracts with Meyer, and one, SAGANTEC in Holland has donated funds, amounting to between \$100k and \$200k for the development and programming of a new electronic control chip.

LOOK → 11. Sussex University has succeeded in producing hydrogen from a breadboard rig based on Meyer's circuitry.

12. In their DTI sponsored report, published in early 1992, on Meyer's patents, experts from Queen Mary and Westfield College of the University of London, were unable to reconcile Meyer's WFC descriptions as presented both in his patents and his other technical papers with currently established scientific doctrine and literature. However they left open the possibility that WFC might prove to be an altogether new development.

13. The origins of this so-called 'new' development has been attributed partly to James Clerk-Maxwell's work, particularly his 'Treatise on Electricity and Magnetism' first published in 1873, where he identified a source of considerable energy in the vacuum and



partly in Sir Edmund Whittaker's papers published in 1904 in which he proved, in theory, how this energy could be tapped and engineered. During the past 20 years considerable progress has been made on both fronts and the existence of vacuum energy is no longer in dispute. John Archibald Wheeler of Princeton University has measured its flux density as  $10^{93}$  grams/cm<sup>2</sup>. Several distinguished scientists, notably A. Prigogine in 1977, and Moray B. King in 1978, amongst others, have described how this energy could be tapped. Only a very small fraction of the total energy freely and inexhaustibly available, would be required to achieve both the dissociation of water and the ionisation of gases with resultant availability of atomic energy. The mechanism they describe for such tapping includes the application of very high voltage pulses at a frequency which resonates with that of the water molecule. This is similar to and is believed to provide independent collateral for WFC technology.

14. The above phenomena relate to an open system. Since the first and second laws of thermodynamics relate to closed systems they are not being infringed by WFC.
15. The volkswagen engined dune buggy for TACO Phase 1 has already been acquired at no cost to Perkins.
16. At Meyer's request an important component (spools for the Voltage Intensifier Circuit) of the volkswagen conversion equipment has already been manufactured in the UK and another is being negotiated.
17. Meyer's costs are related to prototype equipment.
18. Meyer has delegated the promotion of the marine application of WFC to Admiral Griffin.
19. TACO Phase 2 would be the first world demonstration of a marine diesel.
20. Perkins is at present the only UK company involved and has an opportunity not only to gain exclusive rights to a very substantial market but also to promote a favourable position for the UK as a whole in this potentially important field.

#### URGENCY

21. An urgent decision is needed if the agreed TACO programme is to be met and the UK is to achieve, through Perkins, a favourable position in Europe.
22. Connections with UK gas turbine (both marine and aero), power generation and heavy marine diesel (e.g. 30k hp) companies need to be made as soon as possible.
23. HRH the Duke of Kent, who has taken a close interest in the subject and agreed to open any London demonstration, will be holding his programme meeting covering next July on 16th February.
24. The owner of the 'Brunel' (now fitted with a Perkins Type 6.3544M marine diesel) needs as much notice as possible for the London demonstration, due, according to the TACO agreement, to take place in July 1993.

A.T.F.G.G.  
27.1.93

## Free Energy

# PHENOMENA OF THE FREE ENERGY IN NATURE AND TECHNOLOGY

by Dr. Ing. Jacob Huber, Kehrsatz, Switzerland

The author is amongst those scientists who are not satisfied with the declarations of orthodox physics on, for example, the subject of "Phenomena of Gravity." Dr Huber has already reported in raum&zeit No.35 about the "Ether and its influence on the Physics of Open Systems" and in the same edition has published a study entitled "Calculation of the Planetary Orbit". Particularly, in the first of these studies, Huber supplied the mathematical proof that energy conversion is possible in open systems. In the article which now follows he investigates the Phenomena of Free Energy, as they appear, especially, in a flash of lightning. The enormous energies released by lightning form part of the "Mechanism of Energy in Nature", of which Tesla spoke.

The subject of Phenomena of Free Energy (FE) in Nature and Technology recalls Pioneer Viktor Schauburger's declaration : "First understand Nature, then copy it." Such a procedure not only corresponds to the human order, but also leads most definitely to a natural technology.

The question now arises as to how far we have got in pursuing this objective. The example of the natural phenomenon of lightning is taken as a definition of the position.

Lightning is an electrical discharge which occurs between clouds or from cloud to earth. Of particular interest are the circumstances of its generation and the origin of its important energy. Even believing, with good reason, the ocean to be the source of FE, it is of great significance to know the conditions under which such an enormous concentration of energy is achieved and developed in lightning.(see Ref. (1))

The relationships derived from a mathematical theory of kinetically coupled vector fields, named "Etheric", are drawn up in Table 1. Such vector fields are, amongst others, the substantial electrical field intensity  $\vec{E}$  and the magnetic flux density  $\vec{B}$  within the lightning phenomenon. The equations (37) and (38) show how the kinetic field magnitudes  $\vec{E}$ ,  $\vec{B}$  are coupled to the dormant field magnitudes  $\vec{E}_0$  and  $\vec{B}_0$  by the reference speed (8).

Complex vector field	
(1)	$\vec{X} = \vec{Y} = ic\vec{Z}$ Open significance Euler-Gl
(2)	$\frac{d\vec{X}}{dt} = \frac{\partial\vec{X}}{\partial t} + (\vec{V}\nabla)\vec{X} = 0$ $\vec{X} = \vec{\nabla} \times \vec{A}, \frac{d\vec{A}}{dt} = \vec{\nabla} \psi$ Energy sea Maxwell-Gl with $\nabla\vec{V} = 0$
(7)	$\vec{\nabla} \times i\vec{X}c = -\frac{\partial\vec{X}}{\partial t} - \vec{V}(\nabla\vec{X})$ Coupling condition
(6)	$\vec{V} \times \vec{X} = -ic(\vec{X} - \vec{X}_0)$ $\vec{X}_0 = \vec{\nabla}\psi$
(8)	$\vec{u} = \frac{\vec{V}}{c}$ Reference speed
Solution of (6)	
(10)	$\vec{X} = \frac{1}{1-u^2} [\vec{X}_1 - \vec{u}(\vec{X}_1\vec{u})]$
(11)	with $\vec{X}_1 = \vec{X}_0 + \vec{u} \times i\vec{X}_0$
Electrodynamic	
(34)	$\vec{X} = \vec{E} + ic\vec{B}$
(35)	$\vec{E} = \vec{E}_0 + \vec{V} \times \vec{B}$ $\vec{V} \equiv \vec{V}_{\text{Observer}} = -\vec{V}_{\text{Origin}}$
(36)	$\vec{B} = \vec{B}_0 - \frac{\vec{V}}{c^2} \times \vec{E}$
(37)	$\vec{E} = \frac{1}{1-u^2} [\vec{E}_1 - \vec{u}(\vec{E}_1\vec{u})]$ with $\vec{E}_1 = \vec{E}_0 + \vec{V} \times \vec{B}_0$
(38)	$\vec{B} = \frac{1}{1-u^2} [\vec{B}_1 - \vec{u}(\vec{B}_1\vec{u})]$ with $\vec{B}_1 = \vec{B}_0 - \frac{\vec{V}}{c^2} \times \vec{E}_0$
Table 1 Etheric [1] 10.10.90 Hu	

In these connections the resonant factor,

$$(60) \quad R = 1/\sqrt{1-u^2}$$

which can, when approaching  $u^2 \approx 1$ , adopt very high values, is of particular interest.

The electrical flow of density  $\vec{G}$  experiences, in a magnetic flux of density  $\vec{B}$ , an electrodynamic energy density

$$(61) \quad \vec{k} = \vec{G} \times \vec{B}$$

Particularly flow  $\vec{G}$  undergoes in its own magnetic flux  $\vec{B}_G$  the pinch power density

$$(62) \quad \vec{k}_p = \vec{G} \times \vec{B}_G$$

Regarding  $\vec{G}$  and  $\vec{B}_G$  it is a question of kinetic field magnitudes which, because of (60), can differ considerably from the dormant field magnitudes as evidenced by relationships (37) and (38).

The resulting pinch power density (62) on a circular lightning cross section is

$$(63) \quad \begin{aligned} k_p &= (\mu/2)\vec{G} \times (\vec{G} \times \vec{r}) = \\ &= -(\mu/2)\vec{G}^2\vec{r} = \\ &= -(\mu/2\rho^2)\vec{E}^2\vec{r} \end{aligned}$$

This has a centripetal effect which means compressing the discharge with a tendency to cut it off. The energy sea, of density  $e_{FE}$ , is under universal pressure

$$(64) \quad p_{FE} = e_{FE}$$

This pressure works in the same way as the pinch power of the starting discharge, through loading compensation, and amplifies the loading flow by a corresponding flow of density  $G_{FE}$ . This is decisive when  $u^2$  of

the plasma of the discharge is approaching the value of 1. Then the lightning is substantially fed by the FE of the ocean.

The resonance depends on the movement, i.e. the orthorotation illustrated in Figure 2.

The operation of the lightning discharge further results in the following relations

$$(65) \quad G = E/p$$

i.e. Ohm's Law for the specific resistance p.

$$(66) \quad k_G = \eta E_G$$

i.e. the electrical power density on a loading density  $\eta$ .

With (65) and (66) results from (62), the pinch-field

$$(67) \quad E_p = k_p/\eta = (E_G/\rho\eta) \times B_G = bE_G \times B_G$$

in which

$$(68) \quad b = 1/\rho\eta = V_G/E_G$$

stands for the mobility of the load carrier.

The pinch-field has a pinch-flow density  $G_p$  and with  $B_G$  gives

$$(71) \quad E_1 = (E_p/\rho\eta) \times B_G = -B_G \times [(E_G/\rho^2\eta^2) \times B_G] = -(B_G/\rho\eta)^2 E_G$$

This relation states that  $E_1$  works opposite to  $E_G$ . So the resulting field magnitude within the discharge is

$$(72) \quad E_{res} = [1 - (bB_G)^2] E_G$$

Particularly for  $(bB_G)^2 = 1$  the effective field magnitude of the loading is nullified. Subsequent to (63) the already mentioned possibility of self-cutting-off takes place. Thus the previously bound electro-magnetic energy is released. It provokes air vibrations which are recognised as thunder.

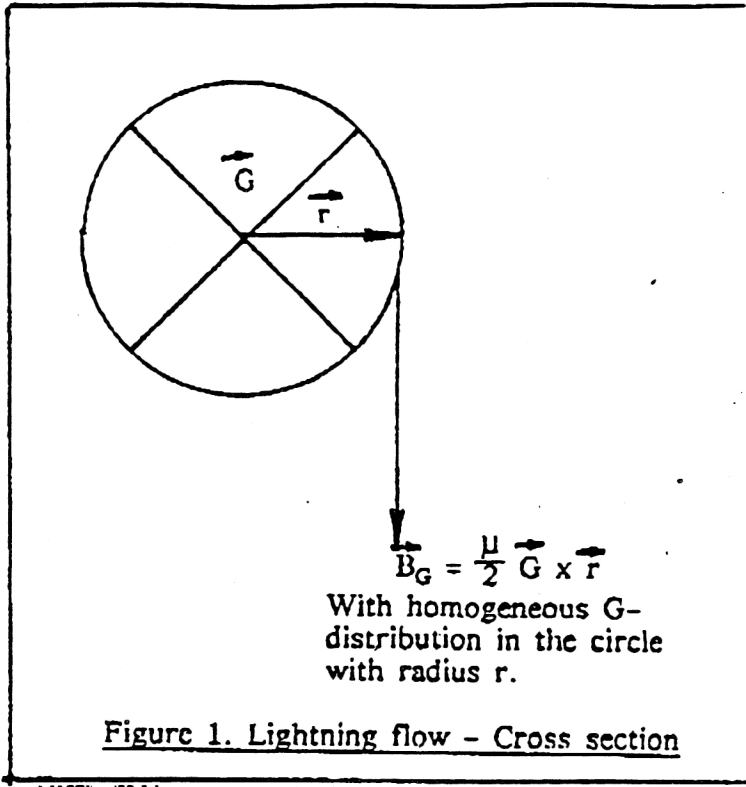

Figure 1. Lightning flow - Cross section

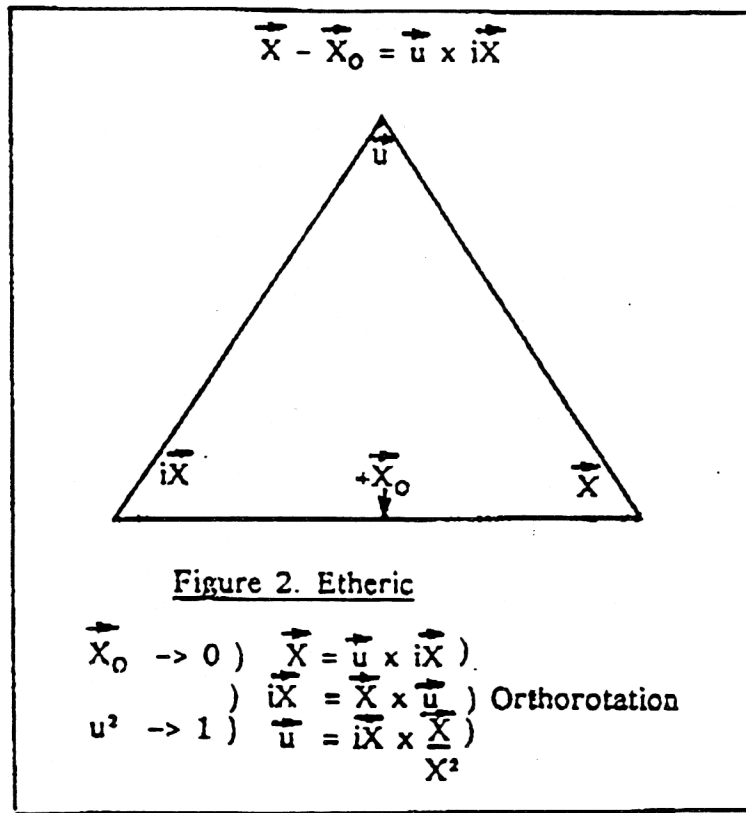

Figure 2. Etheric

$$\begin{aligned} X_O \rightarrow 0 & \quad \vec{X} = \vec{u} \times \vec{iX} \\ & \quad \vec{iX} = \vec{X} \times \vec{u} \\ u^2 \rightarrow 1 & \quad \vec{u} = \vec{iX} \times \frac{\vec{X}}{X^2} \end{aligned} \quad \text{Orthorotation}$$

Consequently the lightning phenomenon is mainly determined by two conditions :

1) The resonant condition determines the concentration of free energy in the lightning discharge.

$$(73) \quad u^2 = (v/c)^2 = 1$$

2) The cut-off condition determines when the bound energy in the lightning is released.

$$(74) \quad (bB_G)^2 = 1$$

The lightning functions like a "FE valve-pump."

Closely analogous considerations are also valid for the generation and demise of a tornado, as can be proved by the formulation  $X = a + icw$ . According to recent investigations, beside the classical weather mechanism, electrical discharges in the form of spherics appear to govern initiation.

Acknowledging the significance of this natural phenomenon both as a dangerous threat over wide areas and, probably, as a source of energy to be exploited, further research is necessary.

In connection with the lightning phenomenon, the so-called lightning machines (Testatika-, Searl-, Newman- machine etc) for the exploitation of free energy should be mentioned. The afore mentioned conditions 1) and 2) have to be fulfilled for them too. The relevant steps to be taken have to be considered on a case by case basis. (60) plays a major part in the sought after over-one-factor. However mobility (68) is of decisive importance for any exploitation.

Here the question arises whether, according to Stan Meyer for the Water Fuel Cell, the mobility of the electrolytes in the sense of (72) may be responsible for the fact that, in this cell, less energy is needed to separate  $H_2$  and  $O$  than is produced by combining them.

As can be gathered from this report, there is still a lot more research to be done. Further clarification is needed for greater understanding of the FE phenomena and in particular for the realization of optimal technical solutions.

To answer the topical question over the necessity of new energy sources and the advancements of knowledge, it is necessary further to investigate the possibility of putting them into effect and the moral and ethical issues involved.

Reference: [1] Record of the International Congress for Free Energy, Einsiedeln 1989, Chapter 8

WATER FUEL CELL (WFC)  
ACCOUNT OF VISIT TO STANLEY MEYER (SM)  
OHIO 6th - 8th OCTOBER 1992  
by PERKINS TECHNOLOGY LTD (PTL)  
and ADMIRAL GRIFFIN (AG)

Introduction

1.1 The PTL representatives were :-

Mr T.W.E.Downes. Managing Director (TD)  
Mr G.Purkins. Engineering Development Manager (GP)  
Dr M.Graham PhD, Chemist and a Project Leader. (MG)

1.2 All had been extensively briefed on the subject as indexed in Annex A. Consequently PTL had developed a positive attitude to WFC technology and wished to contribute to its success. Subject to their confidence being confirmed after meeting SM in person and hearing what he had to say and demonstrate in his laboratory in Grove City Ohio, they would work out details of future joint action with SM.

Programme

2.1 TD, GP and AG met SM at Columbus Airport at about 2000 on Tuesday 6th October and had some introductory talks pending MG's arrival about 2½ hours later. We were then taken to our hotel by SM who picked us up at 0800 on Wednesday 7th October for talks in his laboratory in Grove City. There SM began with a new video film of the 'dune buggy' in action coupled with the salient features of his recent technological developments. With the exception of a new, versatile and controllable chip, which remains under development by 'SAGANTEC' in Holland for about another 2 months, the remainder is in an advanced engineering-for-production state as part of a complete system. SM then gave an up-to-date presentation of his WFC technology assisted by slides, and handed over copies of his video tape and latest Technical Brief to both GP and AG. This Brief embraces the following Memos:-

- WFC 420. Hydrogen Fracturing Process
- " 421. Quenching Circuit Technology.
- " 422DA. Hydrogen Gas Management System.
- " 423DA. Water Fuel Injection System.
- " 424. Atomic Energy Balance of Water.
- " 425DA. Dynamic Voltage Stimulation.

2.2 A considerable discussion followed. The main result was PTL's decision fully to support SM and his WFC technology, subject to 'proof of concept' and costing. PTL's title

for this would be Project 'TACO'. 'Proof of concept' would consist of a successful demonstration at PTL's laboratory at Peterborough of a Volkswagen engine, identical to that now in the 'dune buggy', which would be fitted with the necessary conversion parts as supplied and advised by SM. This would be referred to as Phase 1. Phase 2 would be put in hand as soon as judged prudent in the course of Phase 1. It would consist of the provision by PTL of a Type 6.3544M marine diesel, identical to that now fitted in the 'Brunel' Thames ferry, together with a dummy load and instrumentation. An additional set of conversion parts for this diesel engine would be supplied by SM. When this engine had been successfully tested at Peterborough it would, subject to the owner's agreement, be applied to the 'Brunel' either by complete substitution or by conversion, for as long as required for public demonstration. At an appropriate stage in Phase 2 PTL would, as Phase 3, identify other market sectors, products and programmes in the reciprocating engine field (both petrol and diesel) including the powers required for merchant ship propulsion, observing that the maximum scope of SM's currently available equipment is 450 hp. Having reached agreement thus far, TD and MG set off from Columbus airport during the afternoon, leaving SM to work out further details with GP and AG before their departure for London p.m. the next day.

2.3 The programme on Thursday 8th October began with a bench demonstration of the dissociation of water into hydrogen and oxygen by pulsed voltage stimulation. Dissociation was observed to begin at about 10 volts and increased markedly with voltage. The maximum observed current was less than 1 milliamp. The glass vessel and its attached pipework and pressure gauge remained at room temperature throughout. Hydrogen was released, initially as a cool jet, but when subsequently lit by a match the flame melted stainless steel wire at a temperature of about 3,000°F.

2.4 Broad programmes for Phases 1 and 2 were then agreed, as illustrated in Annex B.

#### Other Points made in Discussion.

3.1 SM is concerned that the concentration of his project in him, his laboratory and even in the United States, renders it vulnerable to various kinds of hostile action; he has numerous examples of threats, from both within and outside the US, on record. Since he has recently obtained security clearance to publicise and demonstrate outside the US any aspect of WFC technology which is not militarily classified, he wishes to disperse his activities as much as possible. He wishes to do so initially to and, in due course, through the UK to Europe. Hence his welcome to PTL.

3.2 Whilst PTL would be SM's main UK partner in the field of all reciprocating engines, two other main areas need to be addressed as soon as possible, namely gas turbines for

aircraft and ship propulsion and power generation. AG undertook to pursue both these areas. Meanwhile SM recognised that some 12 conversion kits might soon be required for the UK.

3.3 TD accepted that AG should continue to brief the DTI, MoD, and any other interested parties in the UK on the general aspects of these talks. The matter of a 'confidentiality agreement' between SM, TD and AG, to cover release of propriety technical details, is still under discussion by SM with his legal adviser.

3.4 The Phase 2 plan needs to be discussed and agreed with the owner of the 'Brunel', Mr C.Livett of Livett Launches. AG would take action.

3.5 Phase 1 demonstrations would be handled by PTL and staged at Peterborough. Whilst Phase 2 demonstrations are expected to include the 'Brunel' on the Thames, they might also include WFC application to gas turbines and power generation. AG would initiate action with SM and GP when the situation on Point 3.2 above had developed.

3.6 SM estimated that the cost in production of vehicle conversion kits would be about \$1,500 for a car and about \$3,500 for a truck. (The higher cost for trucks reflected their more robust requirement.)

3.7 SM referred to previous discussion with AG about 'hyperdrive', which is a radically advanced development of WFC technology and of particular application to ships. SM would send more details to AG.

3.8 The 6 in number Voltage Intensifier Circuit bobbins which AG had had manufactured in the UK at SM's request, had arrived safely and were of the necessary quality.

3.9 In the same way as SM is making his basic WFC technology unrestrictedly available on commercial terms, it was his policy to ensure that any new methods or improvements which his customers might devise would be equally transferable.

3.10 There seemed to be no insuperable problem about the 'Brunel' conversion, though the fact that the fuel pump would have to pump water instead of dieso needs to be addressed.

3.11 The precise cost and form of commercial agreement between SM and PTL was in hand with GP. The broader aspect of a global commercial plan was not discussed.

3.12 Photographs taken 7/8 October, Annex C. SM's News Release, No. 9 Annex D.  
Distribution See Annex B

A.T.F.G.G. 13.10.92



BRIEF FOR MEETING BETWEEN  
PERKINS TECHNOLOGY LTD AND ADMIRAL GRIFFIN  
RE DEMONSTRATION OF TYPE 6.3544M ENGINE  
IN MV BRUNEL

ANNEX A

1600 WEDNESDAY 2ND SEPTEMBER 1992  
AT THE INSTITUTE OF DIRECTORS

INDEX

<u>ANNEX</u>	<u>DATE</u>	<u>ITEM</u>	<u>REMARKS</u>
A	29.6.90	AG fax to SM	<i>Brunel's</i> engine and photos. Distributors in US (Workshop manual posted to SM, 7.7.90)
B	18.7.90	Fax AG to SM	Contact with KW, who has Patent 4936961. Kember en van Quist, diesel spark plugs.
C 1	14.9.90	AG letter to KW	Introduces proposition
C 2	28.9.90	Fax SM to AG	Machining cost for conversion of fittings.
D	17.6.91	ML, KH, AG Memo	Appreciation. Universal Adoption of H
E 1	30.6.91	AG letter to CL	Request for <i>Brunel</i> time charter
E 2	22.7.91	CL letter to AG	Quotation for <i>Brunel</i> time charter.
F 1	25.8.91	AG fax to SM	Plea for application to Marine Diesel
F 2	* 26.8.91	GP fax to AG and SM	Fuel pump mounting details
F 3	19.9.91	Invoice + air freight	Golden Arrow Marine fuel pump to SM
G 1	12.9.91	Memo by AG	Outline plan for Demo, on previous UK basis.
G 2	15.8.91	AG letter to MC	Estimated cost of above Demo.
G 3		Map of Tower Area	
G 4	14.9.91	World Trade Centre.	Quotation for Devon House.
H	* 2.10.91	Meeting at P.Dev.Ltd	TD, GP and AG.
I 1	Dec 1988	Instructions	SM's Dealership Deals
I 2	3.8.91	Memo	Appreciation by AG of Licencing Policy
I 3	16.8.92	Note of meeting	Sir K StJ, Mark Cliff & AG. Commercial plan.
I 4	25.3.92	Letter AG to SM	International Business Structure. Proposals.
J 1	13.4.92	Letter Bramble to AG	Covering Loughton Report on SM's patents.
J 2	18.4.92	AG letter to Bramble	Collaterals for WFC technology.
K		Memo	Draft Confidentiality Agreement.
L		Maps	Ohio & Columbus area.
M	* 7.8.92	Memo	Account of AG visit to SM Ohio, 3-4 Aug.'92.
N	19.8.92	FAX from Sagantec	Offer to develop and programme chip

\* Not included.

PROJECT 'TACO'

PHASE 1

DEMONSTRATION OF VW DUPLICATE AT PTL FOR PROOF OF CONCEPT TESTING

1. SM TO COMPLETE CHIP SPECIFICATION.
2. PTL PROCURE VW 1600cc ENGINE.
3. SM PROCURE DUPLICATE WFC CONVERSION KIT.
4. PTL TEST BED RIG AND INSTRUMENT VW ENGINE
5. SM FIT WFC CONVERSION KIT TO ENGINE AT PTL
6. PTL RUN EVALUATION TESTS AND PASS COPY OF ALL TEST DATA TO SM.

PHASE 2

DEMONSTRATION OF TYPE 6.3544M ENGINE FOR THE 'BRUNEL'

1. PTL PROCURE 6.3544M ENGINE FOR WFC RETROFITTING.
2. PTL AND SM DESIGN MINIMUM CHANGE RETROFIT KIT - MAXIMUM USE OF VW KIT WHERE POSSIBLE.
3. SM PROCURE WFC RETROFIT KIT.
4. SM FIT KIT AT PTL.
5. PTL RUN TEST BED EVALUATION.
6. PTL EITHER :-
  - A) CONVERT THE 'BRUNEL' ENGINE WITH THE WFC KIT,
  - OR
  - B) INSTAL THE TEST BED EVALUATION ENGINE.
7. PTL AND AG ORGANISE APPROPRIATE PRESENTATION EVENT.

PHASE 3

MARKET SECTOR IDENTIFICATION AND PROGRAMMING

1. PTL RECOMMEND A PHASER TRUCK PROGRAMME.
2. PTL RECOMMEND A PASSENGER CAR PROGRAMME.
3. PTL AND AG RECOMMEND A MARINE PROGRAMME.
4. PTL CONSIDER NEW ENGINE DESIGN IMPLICATIONS.

PROJECT 'TACO'

PHASE 1

DEMONSTRATION OF VW DUPLICATE AT PTL FOR PROOF OF CONCEPT TESTING

1. SM TO COMPLETE CHIP SPECIFICATION.
2. PTL PROCURE VW 1600cc ENGINE.
3. SM PROCURE DUPLICATE WFC CONVERSION KIT.
4. PTL TEST BED RIG AND INSTRUMENT VW ENGINE
5. SM FIT WFC CONVERSION KIT TO ENGINE AT PTL
6. PTL RUN EVALUATION TESTS AND PASS COPY OF ALL TEST DATA TO SM.

PHASE 2

DEMONSTRATION OF TYPE 6.3544M ENGINE FOR THE 'BRUNEL'

1. PTL PROCURE 6.3544M ENGINE FOR WFC RETROFITTING.
2. PTL AND SM DESIGN MINIMUM CHANGE RETROFIT KIT - MAXIMUM USE OF VW KIT WHERE POSSIBLE.
3. SM PROCURE WFC RETROFIT KIT.
4. SM FIT KIT AT PTL.
5. PTL RUN TEST BED EVALUATION.
6. PTL EITHER :-
  - A) CONVERT THE 'BRUNEL' ENGINE WITH THE WFC KIT,
  - OR
  - B) INSTAL THE TEST BED EVALUATION ENGINE.
7. PTL AND AG ORGANISE APPROPRIATE PRESENTATION EVENT.

PHASE 3

MARKET SECTOR IDENTIFICATION AND PROGRAMMING

1. PTL RECOMMEND A PHASER TRUCK PROGRAMME.
2. PTL RECOMMEND A PASSENGER CAR PROGRAMME.
3. PTL AND AG RECOMMEND A MARINE PROGRAMME.
4. PTL CONSIDER NEW ENGINE DESIGN IMPLICATIONS.

ANNEX C

G.Purkins, T.Downes, M.Graham, S.Meye

'Dune Buggy'

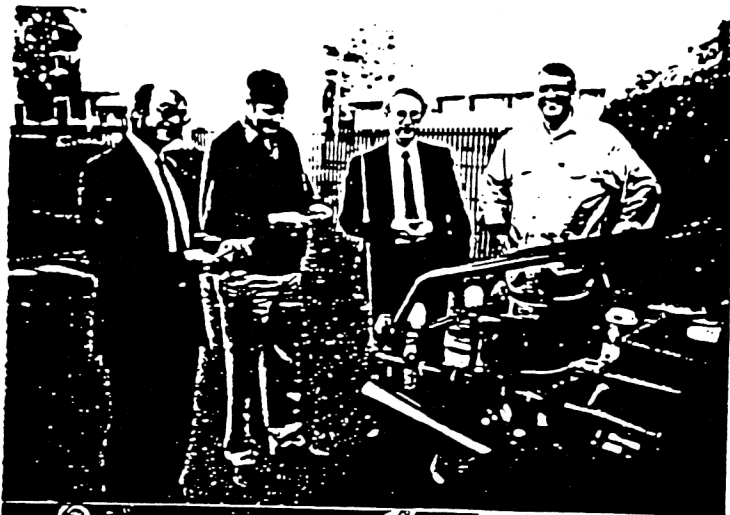

H flame. 3k degrees F

Treaty of Taco Bell

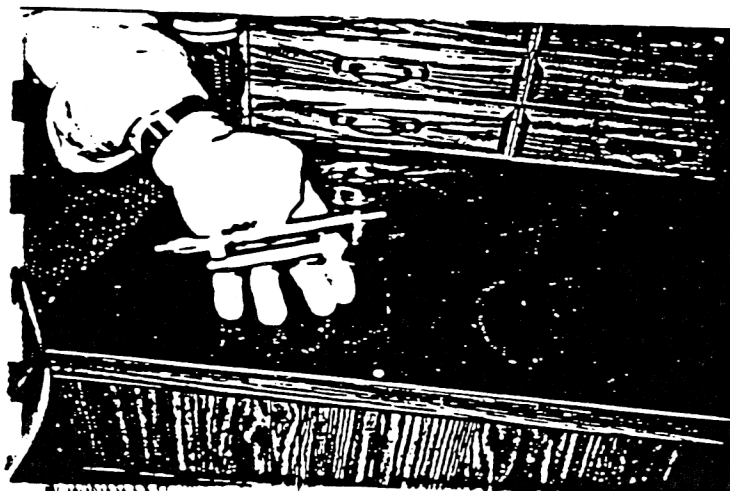

Fuel Injector dismantled



PERKINS GORDEN PURKINS, TONY DOWNS, MIKE GRAHAM VIEWING DUNE BUGGY AS INVENTOR STAN MEYER SHOWS THE WATER FUEL INJECTORS



PERKINS GORDEN PURKINS, TONY DOWNS, MIKE GRAHAM VIEWING HOW WFC WATER FUEL INJECTION SYSTEM® UPGRADE UNIT BEING RETROFITTED TO DUNE BUGGY

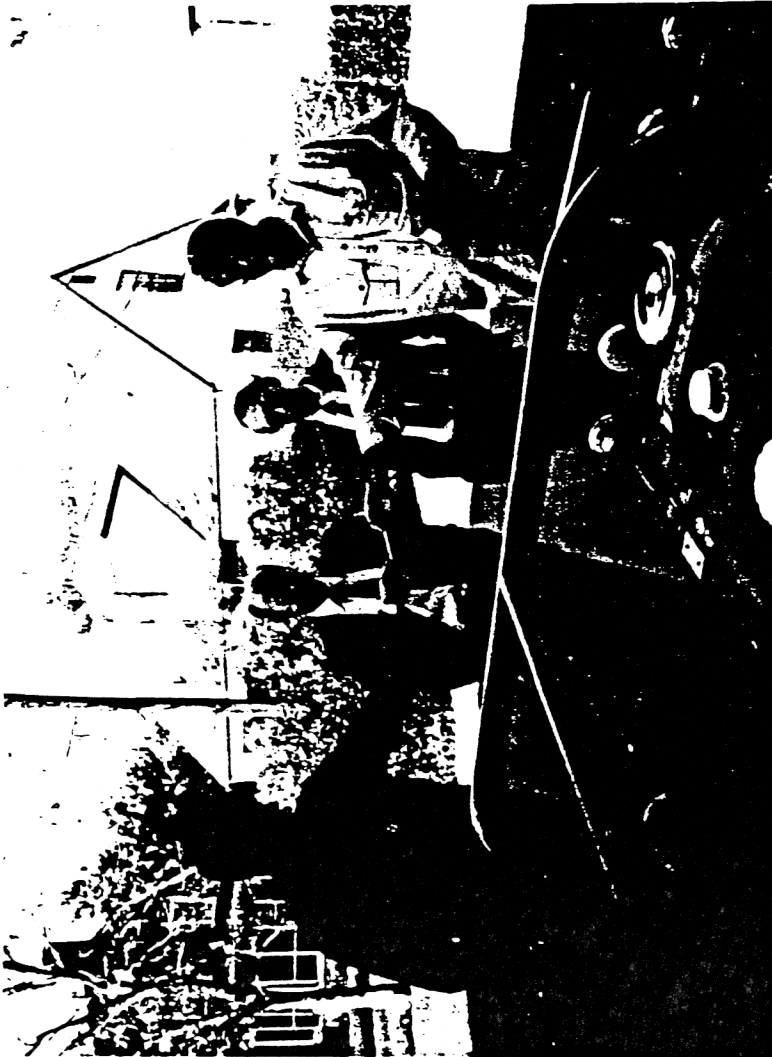

PERKINS TONY DOWNS, GORDEN PURKINS, MIKE GRAHAM, AND INVENTOR STANLEY MEYER TALKING ON HOW THE WATER FUEL INJECTION SYSTEM ® IS TO BE RETROFITTED TO A 6.3544M MARINE DIESEL PERKIN ENGINE FOR THE PURPOSE OF TRANSPORTING SIR ADMIRAL GRIFFIN ON THE THAMES RIVER PASS BRITISH PARLIAMENT WHILE IN SESSION TO CREATE NAVAL HISTORY

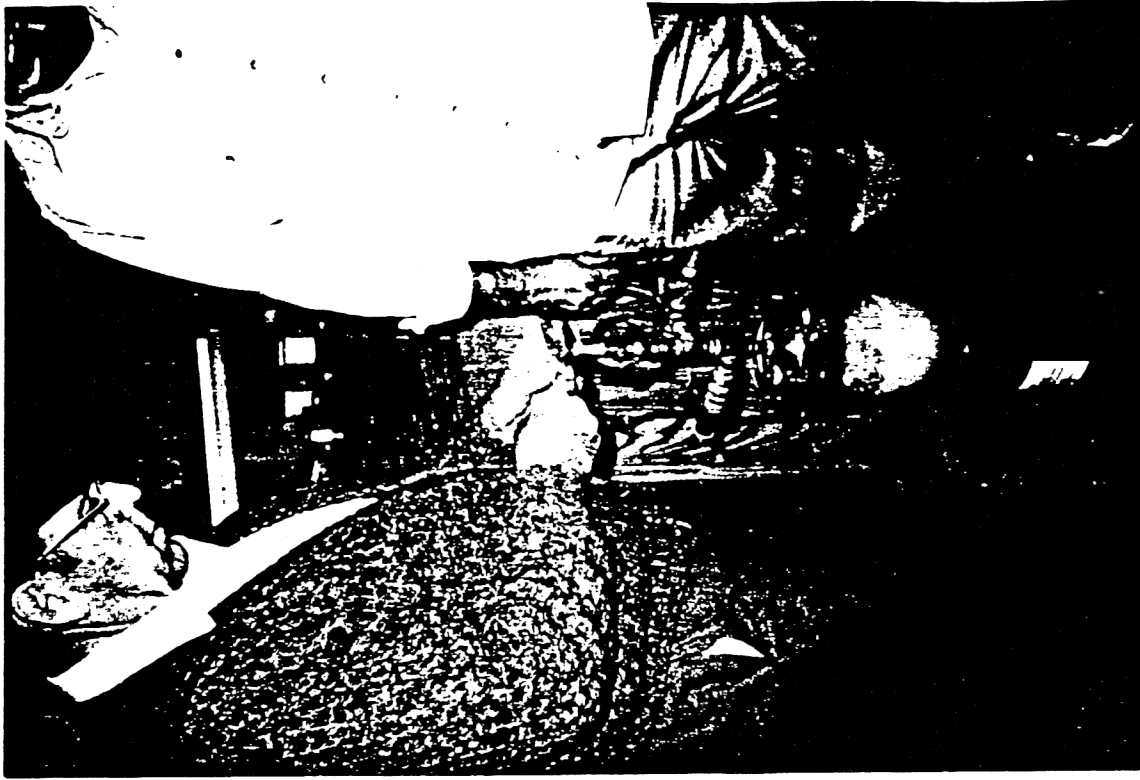

CHARLES HOLBROOK MELTING STAINLESS WIRE FROM HYDROGEN/OXYGEN GASES BEING EMITTED FROM TUBULAR-ARRAY WATER FUEL CELL USING WATER AS FUEL

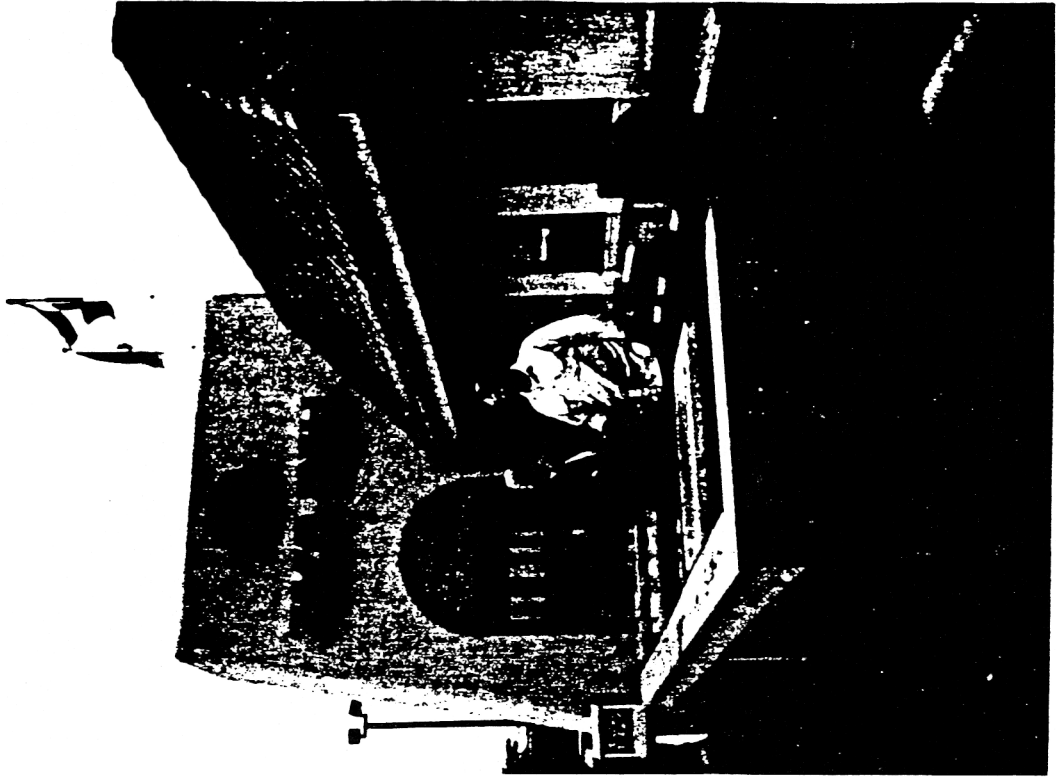

PERKINS GORDEN PURKINS AND INVENTOR  
STANLEY MEYER AFTER NEGOTIATING  
"THE TREATY OF TACO BELL"



SIR ADMIRAL TONY GRIFFIN HOLDING VOLTAGE  
INTENSIFIER CORE ASSEMBLY GROVE CITY LAB  
OF INVENTOR STANLEY MEYER



INVENTOR STANLEY MEYER NEGOTIATOR  
AT THE "THE TREATY OF TACO BELL"

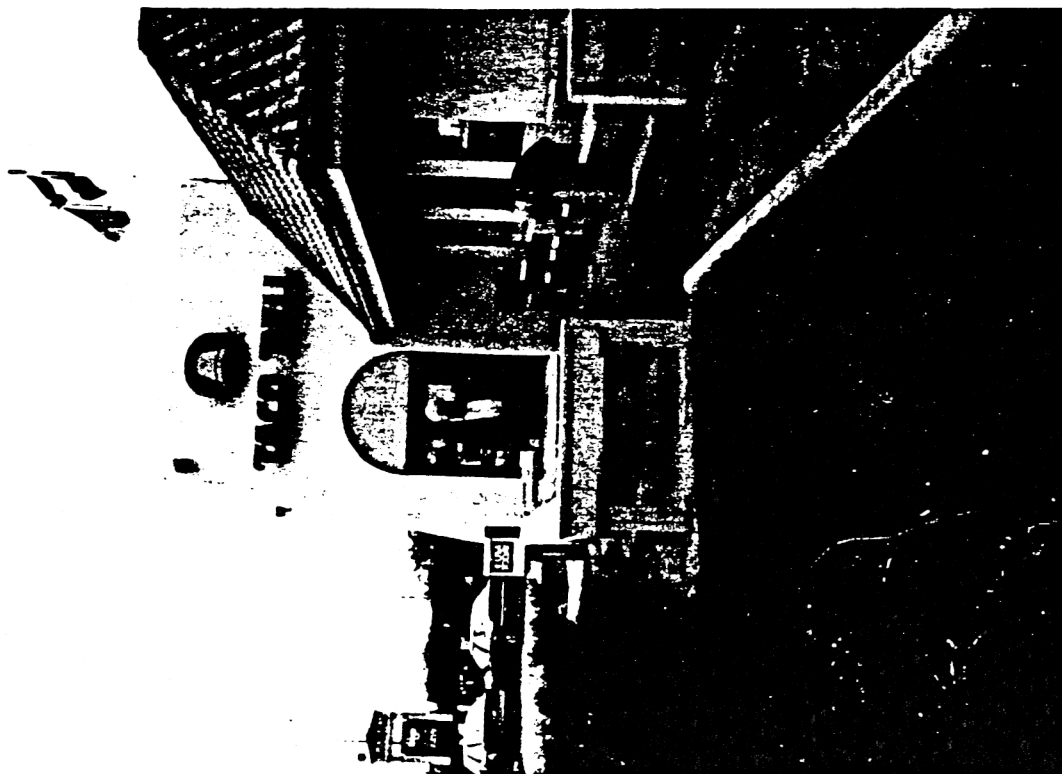

SIR ADMIRAL TONY GRIFFIN PARTICIPANT  
AT THE "THE TREATY OF TACO BELL"



Moat Cottage  
The Drive  
Bosham  
West Sussex PO18 8JG  
UK

4th July 1993

WATER AS FUEL

Dear Stan,

HAPPY INDEPENDENCE DAY !

I enclose a copy of my Southampton paper which has to be in the hands of the Institute during the coming week for printing and improvement, I hope, in the quality of some of the figures, especially the photographs.

This version, (the sixth draft) is technically the same as the one which I sent to you on the 17th May, except that I have substituted a different, and hopefully more correct, treatment of the Second Law of Thermodynamics. I have also included a reference to the welcome paper you sent me by Gary Jonson of Kansas State University

The subsequent pages have been substantially altered mainly by deleting the whole section on United Nations Relief Ships and reducing the treatment of cargo submarines in order to increase the balance of the paper in favour of WFC.

I am relieved to say that Dr Harold Aspden, a physicist attached to Southampton University who tells me he introduced you when you spoke at Denver Colorado, had no adverse comments or corrections to make. I hope you are happy too.

Meanwhile I am very glad to report that David Goodrich, the managing director and Chief Executive of British Maritime Technology, (the leading centre of excellence on naval architecture in the UK) has pledged his full support for WFC. I hope to get a similar commitment from Stone Vickers (the main pump-jet company in the UK) when I meet them on 7th July. Unfortunately I have been unable to see Rolls Royce, the marine gas-turbine people at Ansty, but they have orally registered a distinct interest. I shall have more to report when we meet on 18th July.

Mark Cliff sends his apologies about the necessary change to his plans. He will now arrive a day late, i.e. on Monday 19th July, and make his own way by hire-car direct to the Red Roof Inn. I would be grateful if you could let the hotel know that he will need his room for one night instead of two and if Charlie Holdsworth's demo could be run on the morning of Tuesday 20th July. We need to convince Mark that it is 'over unity.'

I hope this means that on Monday 19th July you and I can concentrate on the subject of your plans for demonstrations in Ohio and London, and also how best to promote *hyperdrive*, marine gas-turbines, and heavy slow speed marine diesels. I assume that all is proceeding smoothly with Perkins.

Am very relieved to hear that you managed to steer the tornado out of harm's way. It must have been a thoroughly alarming experience.

With my warmest regards

*Tommy.*

## WATER AS FUEL

Admiral Sir Anthony Griffin

### ABSTRACT

The Earth's main sources of non solar energy are fossil fuels, which cause severe pollution and cannot last indefinitely; nuclear, which is capital intensive, and whose waste disposal is problematical; tidal and wind schemes which are inefficient; and thermal and hydro installations which are efficient but lack flexibility and require major capital investment.

An alternative is water (salt, fresh or distilled) as a cheap and inexhaustible source of global energy which has none of the foregoing disadvantages. The theoretical evidence in support of the relevant technology is briefly described and related to the first and second laws of thermodynamics. Practical evidence is illustrated and the impact of this revolutionary development on the marine industries, with ships floating on their own fuel and thus having no need for either bunkers or ambient air, is indicated.

Much wider and global implications for the environment, industry, defence and political stability are discussed.

### AUTHOR'S BIOGRAPHY

A regular executive officer in the Royal Navy for 42 years, the last 5 of which were spent as Controller of the Navy with responsibility for the development and construction of all new surface ships, submarines, aircraft and weapons. Retired from RN in 1975 to become first Chairman of British Shipbuilders from 1975 -80; President of the Royal Institution of Naval Architects 1981 - 84, and founder member of the British Maritime League and the British Maritime Charitable Foundation in 1982.

# WATER AS FUEL

## INTRODUCTION

In 1972 the Royal Navy examined how the Fleet should be fuelled when current fossil fuels became too scarce, say in the year 2030. They concluded that the fuel of the future was hydrogen but that, as this gas was not normally available in usable form, it would have to be extracted through either the electrolysis of water or nuclear fusion. Neither appeared to be immediately practicable. Electrolysis needed more power than that of the hydrogen it yielded and was too slow a process to meet the demands of an internal combustion engine. This meant that it would have to be stored in either liquid form or in a fuel cell, both of which involved substantial weight or safety problems. Nuclear fusion appeared to be too distant and expensive an alternative.

This position remains the current generally accepted view of hydrogen as a fuel. It has not however deterred numerous inventors from producing for example over 100 hydrogen fuelled cars in the USA, at least 12 in Germany, and 3 in the UK. The latest is Japan's Mazda HRX car and its Wankel engine as shown in Figure 1.



Figure 1. Japan's Mazda HRX Car and its Wankel engine.

This car was described in June 1992 to the 9th World Hydrogen Energy Conference in Paris. Here the papers referred only to various aspects of hydrogen generation through electrolysis, or its storage or its subsequent application. It is worth recalling that in April 1988, the starboard engine of a three engined Tupolev 255 airliner was modified to run on hydrogen which was seen to be embarked in liquid form from a fuel bowser. The aircraft flew for about twenty minutes on its hydrogen powered engine which showed no exhaust except a trail of water vapour. The main attraction in all these cases has been the absence of pollution at the scene of action. However the pollution problem has merely been transferred to the source of the power required to drive the electrolytic process. A schematic diagram of the basic energy sequence of a typical hydrogen powered engine is shown in Figure 2.

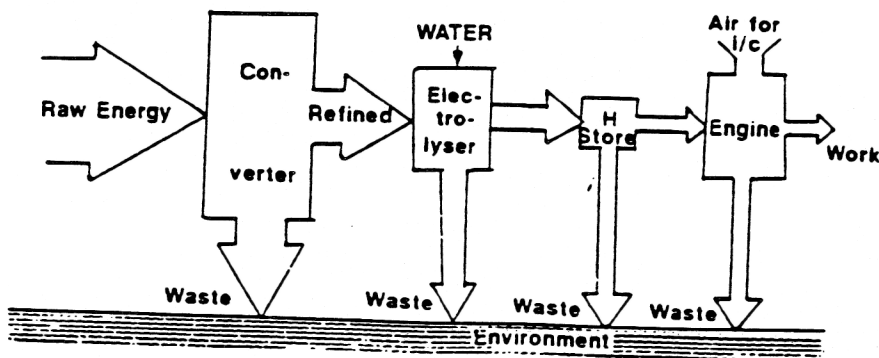

Figure 2. Basic Energy Sequence of a typical Hydrogen Powered Engine.

DR.CORNISH'S HYDROGEN SUPPLY UNIT

A breakthrough was hailed in April 1985 when, at the 13th International Inventions Exhibition in Geneva, Dr Cornish was awarded a gold medal for his Hydrogen Supply Unit. Not long afterwards his photograph appeared in the papers with a hydrogen powered 2cv car in which he planned to cross the Sahara with nothing but water in his fuel tank. A detailed description of the unit together with reports of impressive trials in various cars in New York, appeared in the August 1985 edition of an American publication 'Automotive Engineering'.

Dr Cornish's process was a form of electrolysis in which the energy necessary to dissociate the hydrogen and oxygen atoms in a water molecule was applied through an underwater spark between consumable aluminium electrodes. The process was possibly enhanced by ultra-violet radiation from the spark at a frequency which resonated with that of the first continuum of water. A substantial quantity of hydrogen was generated but although I personally have been experimenting with a preproduction HSU since 1989 I have not succeeded in delivering hydrogen energy amounting to more than 1/3 of that of the electrical energy needed to drive the unit. This is about the norm for conventional electrolysis. A diagram of the HSU is shown in Figure 3.

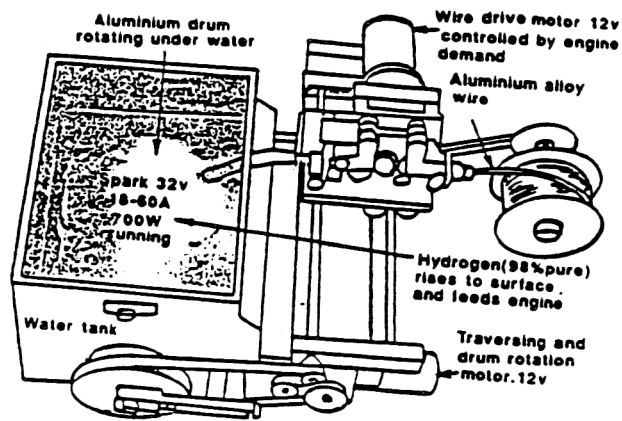

Figure 3. Dr Cornish's Hydrogen Supply Unit

Dr Cornish has now retired to South Africa and all work on his HSU in the UK has ceased. I only mention it because it led to my close association, since mid 1989, with a Mr Stanley A.Meyer, the inventor of an entirely new development, the Water Fuel Cell, in Grove City, Ohio.

STANLEY A.MEYER

Born and brought up in Ohio, Meyer took up a technical career, working mainly in electronics, electrodynamics and particle physics. He worked for some time at the Battelle Institute in Columbus Ohio and has advised NASA on several aspects of the space programme notably over the Gemini space capsule and rocket steering mechanisms. For a time he ran his own business in automobile spare parts and made a fortune with which he financed his subsequent work.

In 1975 he began to apply himself to the dissociation of water and in 1980 patented a process by which the energy of the hydrogen yield vastly exceeded the electrical energy needed to achieve it. The basic concept, to be enlarged on later, is embodied in Meyer's original hydrogen generating equipment which has frequently been demonstrated. I first saw it in the company of Professor Laughton, the Dean of Engineering at London University, and Dr Keith Hindley, in October 1990, and have seen the experiment repeated three times since then. A photograph is at Figure 4.

## WATER AS FUEL

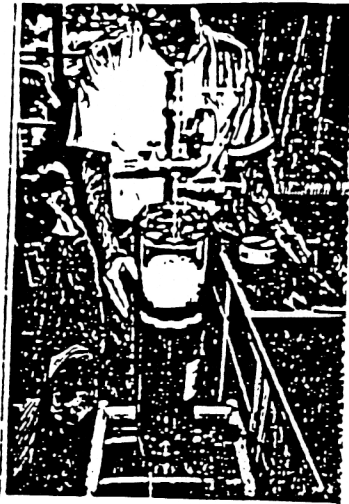

Hydrogen  
Cold glass vessel contain-  
cold tap water  
9 double conc-  
entric stainless  
steel cylinders  
1 mm gap.



Hydrogen  
flame  
burning  
through  
stainless  
steel.

Figure 4. Meyer's Original Water Dissociation Equipment

Meyer subsequently developed a complete system comprising all the components for the conversion of any form of internal combustion engine, either petrol or diesel, reciprocating or gas turbine, of up to about 400 bhp, to be fitted in any land sea or air vehicle. The same principles apply to furnace heating or rocket propulsion.

He first assembled such a system in a rudimentary form and applied it to a 1600cc Volkswagen engine mounted in a running 'dune buggy' in 1985 when he gave a public demonstration as recorded on a video tape held by London University. He then proceeded to refine the design to bring it up to its present preproduction standard. This involved 30 further patents, the majority of which, under a particular regulation of the US Patent Office, needed to be demonstrated before being granted. Some 31 patents have so far been registered, mostly in the USA, Canada and Japan and several are listed under the international Patent Control Treaty.

According to Meyer his dune buggy, travelling at 65 mph, would cover 25 miles per litre of water, (salt, fresh or distilled).

Such a claim is of course revolutionary and what follows next is an attempt to describe, in very broad terms, the theoretical scientific basis of WFC technology and how this relates to the first and second laws of thermodynamics.

### THEORY OF WATER FUEL CELL TECHNOLOGY

This begins with the basic structures of hydrogen and oxygen atoms and how they are combined in the water molecule.

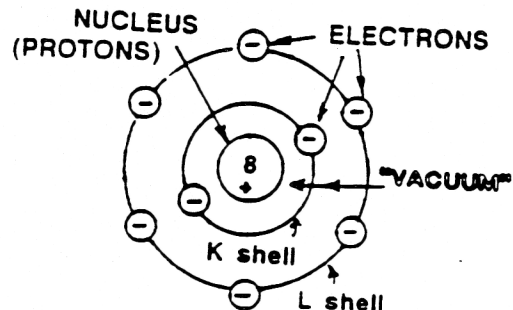
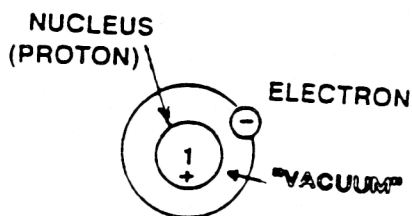

Figure 5. The Hydrogen Atom

Note the orbital paths of the electrons and their 'shells'; the magnetic polarity of an electron and a nucleus; and the space occupied by the so-called vacuum.

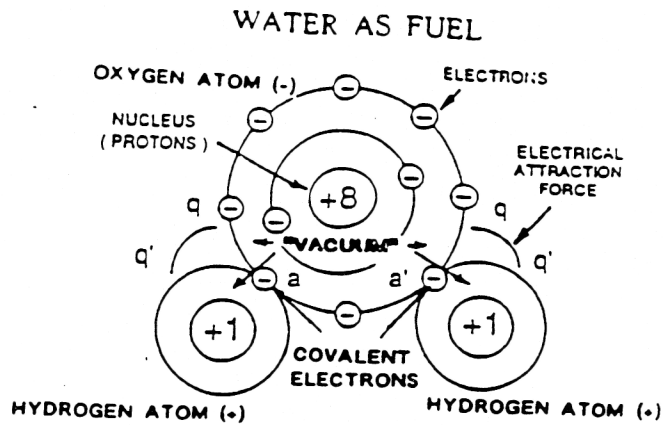

Figure 7. The Water Molecule

Note the presence of the two hydrogen electrons in the 'L' shell of the Oxygen atom. These are known as the covalent electrons which are bonded in position by considerable electrical force. In the case of normal electrolysis the energy needed to break these bonds and produce separate hydrogen and oxygen atoms from water is roughly 3 times the energy of the hydrogen released. It is thus a highly inefficient process because of the considerable amount of waste heat which is generated.

The energy extracted from water by the WFC derives from two distinct but virtually simultaneous processes. The first, the hydrogen fracturing process which dissociates the hydrogen gas from the water molecule and the second, the electron ionisation process, which enhances the explosive energy of the gases released.

### THE HYDROGEN FRACTURING PROCESS. Meyer [1]

The basis of this process is the subjection of the water molecule to very high voltage (20,000 +) pulses at a particular frequency and within positively and negatively charged voltage zones at a very low current (less than 1 milliamp).

The effect is to attract the negatively charged electrons towards the positive voltage zone and the positively charged nucleus towards the negative zone. The electron orbital path is changed from a circle to an ellipse and this, coupled with the effect of pulsing, causes such electrical stress on the molecule that the covalent bonds are separated. Thereafter they require substantial energy to be applied before they can be recombined. Because the current is so low very little heat is generated. It is worth noting that, weight for weight, hydrogen contains about 2½ times the energy of gasoline and the latent energy in the hydrogen content of a pint of water amounts to over 9 million joules, or enough to run 2½ 1000 watt electric radiators for an hour. See Figure 8.

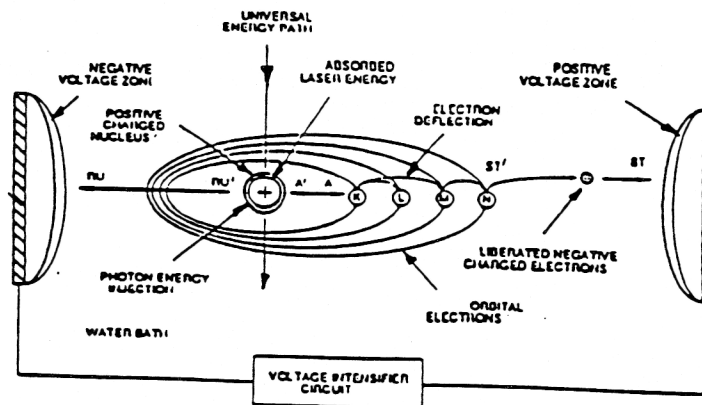

Figure 8. The Hydrogen Fracturing Process

EXPLOSIVE ENERGY ENHANCEMENT

Two distinct questions arise over explosive energy enhancement. First, Where does the additional energy come from ? And second, How is it to be obtained and controlled ?

The answer to the first question is the so-called vacuum within the electron shells. For many years this vacuum was regarded as a void. But James Clerk Maxwell, in his 'Treatise on Electricity and Magnetism' published in 1873, pointed out [2] that the vacuum in fact contains a considerable amount of energy. Subsequent work bears this out and it is now generally accepted that the vacuum is in fact seething with energy which has been variously described as, for example, 'universal energy', 'gravity field energy' or 'Zero Point Energy' (ZPE). John Archibald Wheeler of Princeton University and a leading physicist who worked on the US atomic bomb project, has calculated that the flux density of ZPE is of the order of  $10^{93}$  grams per  $\text{cm}^3$ . [3] It is also recognised that the state of this so called 'sea of energy' is chaotic. Hence it needs to be 'engineered' or made coherent before it can be translated from a microscopic to a macroscopic state. In other words it requires special treatment before it can be tapped and controlled for normal external use.

Various answers, mostly theoretical, have been given to the second question. Recent examples include Ilya Prigogine's book 'Order Out of Chaos'[4] which describes the work which won him the Nobel Prize for Chemistry in 1977, Moray B. King's 'Tapping the Zero Point Energy'[5], Dr J.Huber's paper 'Phenomena of the Free Energy in Nature and Technology'[6], John Davidson's 'The Secret of the Creative Vacuum' [7] and, from the Kansas State University, Gary L.Johnson's 'Electrically Induced Explosions in Water'[8]. Some 30 supposedly practical devices have been made or suggested over the past 80 years, but although some have been demonstrated none has been developed or engineered to a preproduction standard.

Meyer's WFC Technology stands out as the only apparent exception. It has encountered deep scepticism but no argued rejection. Indeed an increasing number of scientists and engineers in the USA, Europe and Asia accept the technology and are prepared to invest in it on the basis of current evidence. A practical demonstration is in fact due to take place within the next few weeks based on a fully designed system, engineered to a preproduction standard and fitted to a running 'dune buggy'.

The technical basis [9] for Meyer's extraction and control of ZPE lies mainly in the effect produced on an atomic nucleus by continuation of the same high voltage pulsing that causes the dissociation of the water molecule. The nucleus consists of one or more positively charged protons bound together with a number of neutrally charged neutrons. The electrical effect of the electron pumping action mentioned earlier causes an annulus to appear in the middle of the nucleus. The ZPE is drawn in a helical motion through the annulus and, in doing so, becomes coherent and hence a usable source of energy. The voltage dictates the size of the annulus and hence controls the energy obtained. Since the basic structure of the atom is retained no  $\alpha$  or  $\gamma$  radiation occurs. The effect might be illustrated by a bath full of water. So long as the plug is in place the water remains still and apparently powerless. However when the plug is removed the water swirls away with a helical motion down the plug hole and, under the influence of gravity, forms a powerful jet which can be directed to do work.

Meyer further stimulates the energy yield by injecting laser energy into the ionised water vapour. A diagram of the energy enhancement system is shown in Figure 9.

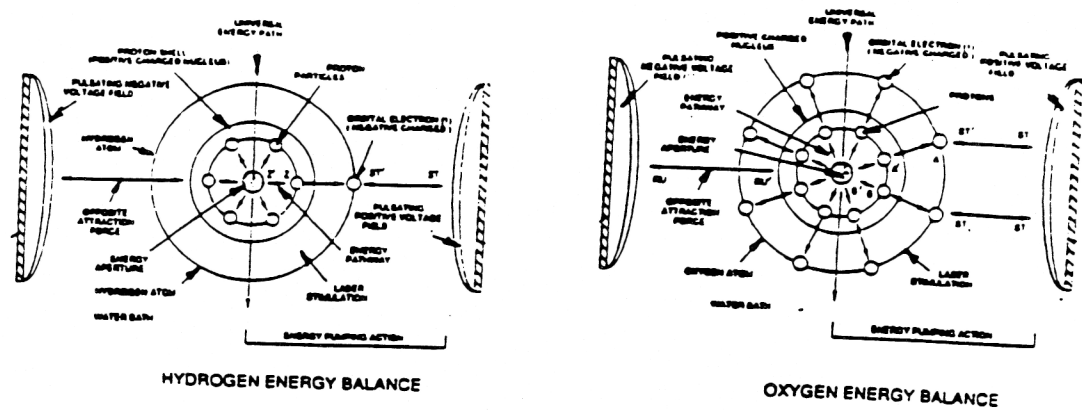

Figure 9. Explosive Energy Enhancement

The hydrogen fracturing process and the energy enhancement of the gas occur almost simultaneously within the fuel injector. This, in an internal combustion petrol or diesel engine, replaces an existing spark plug or diesel fuel injector, and the output is ignited by a high voltage pulse on entry into the cylinder. Consequently the hydrogen does not have to be stored and the fuel tanks of land or air vehicles contain nothing but water. Vessels floating on water need no fuel tanks. The system is thus not only extremely safe but also inexpensive. Meyer has quoted the in-production cost of a conversion kit for a 1600cc Volkswagen engined car as \$1500.

### WFC AND THE FIRST AND SECOND LAWS OF THERMODYNAMICS

WFC technology encounters a credibility gap because it appears to run counter to the long established human laws governing our interpretation of Nature. Some people therefore reject WFC because it appears to be un-natural and just one more spurious claim for perpetual motion. In fact WFC is entirely natural. It merely demonstrates a new and revolutionary way of harnessing what nature has always had on offer. It does not infringe the two main laws of thermodynamics, i.e.:-

**THE FIRST LAW:** *'The total energy of a thermodynamic system remains constant although it may be transformed from one form to another.'* In the case of WFC technology the system is global. The energy required to drive the engine comes from the ZPE contained in water, a virtually inexhaustible source. The exhaust from the engine is water vapour which returns to the atmosphere.

**THE SECOND LAW:** As originally formulated by R.Clausius in 1865, this law states that *'The Entropy of the World strives towards a maximum'*. As recently formulated by Prigogine and Stengers [10] this law 'contains two fundamental elements : (1) a negative one that expresses the impossibility of certain processes (e.g. heat flowing from a cold to a hot source) and (2) a positive, constructive one. It is the impossibility of certain processes that permits us to introduce a function, entropy, which increases uniformly and behaves as an attractor for isolated systems.' It is at maximum when the system is in equilibrium. Non equilibrium is the source of order and brings order out of chaos. Since WFC technology postulates non equilibrium it can be said to be supported by the positive element of this Law.

### THE VEHICLE SYSTEM

The system starts with a normal 12v car battery and a tank full of water (salt, fresh



# WATER AS FUEL

or distilled). Under computer control the Voltage Intensifier Circuit is energised by the battery to generate high voltage pulses at a very low current, <1milliamp, the voltage being responsive to the throttle. Simultaneously water and ambient air are mixed into a water mist which is injected with laser energy and fed into each fuel injector. There it is subject to high voltage pulses which, virtually simultaneously, lead to the separation of the hydrogen and oxygen gases, and the explosive energy enhancement. A specially high voltage pulse, applied at the exit of the fuel injector, ignites the gases as they enter the cylinder. The system is outlined in Figure 10.

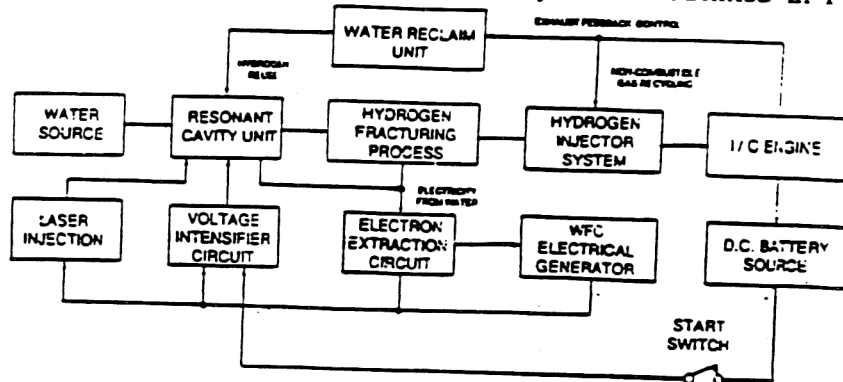

Figure 10. WFC System Schematic for a Car

The Fuel Injector. [11] This highly innovative development accounts for the compactness of the vehicle conversion kit. It replaces the 'resonant cavity unit' which formed a relatively bulky and expensive component of the system as originally designed; eliminates the need for a special hydrogen conduit between the cavity unit and the fuel injection system; and reduces the variety of such systems by allowing any adjustments to be made through a newly designed universal computer. A schematic diagram is shown in Figure 11, and a photograph in Figure 12.

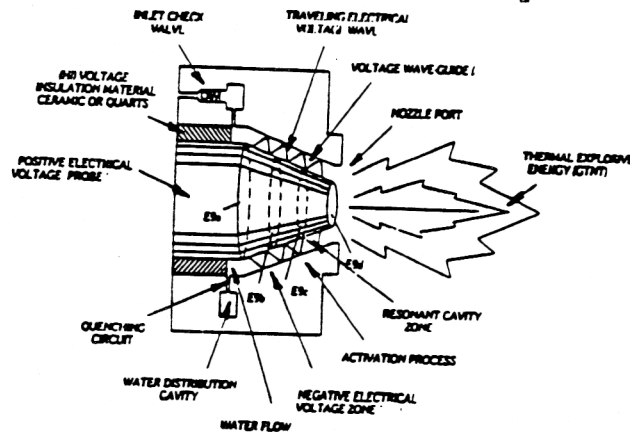

Figure 11. Schematic of Fuel Injector



Figure 12. Photograph of Fuel Injectors.

## WATER AS FUEL

A photograph of the nearly completed 'Dune Buggy' is shown in Figure 13. The missing parts at the time the photograph was taken in 1992 are the computer which is located in the front compartment and the voltage intensifier coils which are to be mounted on the body frame each side of the engine.

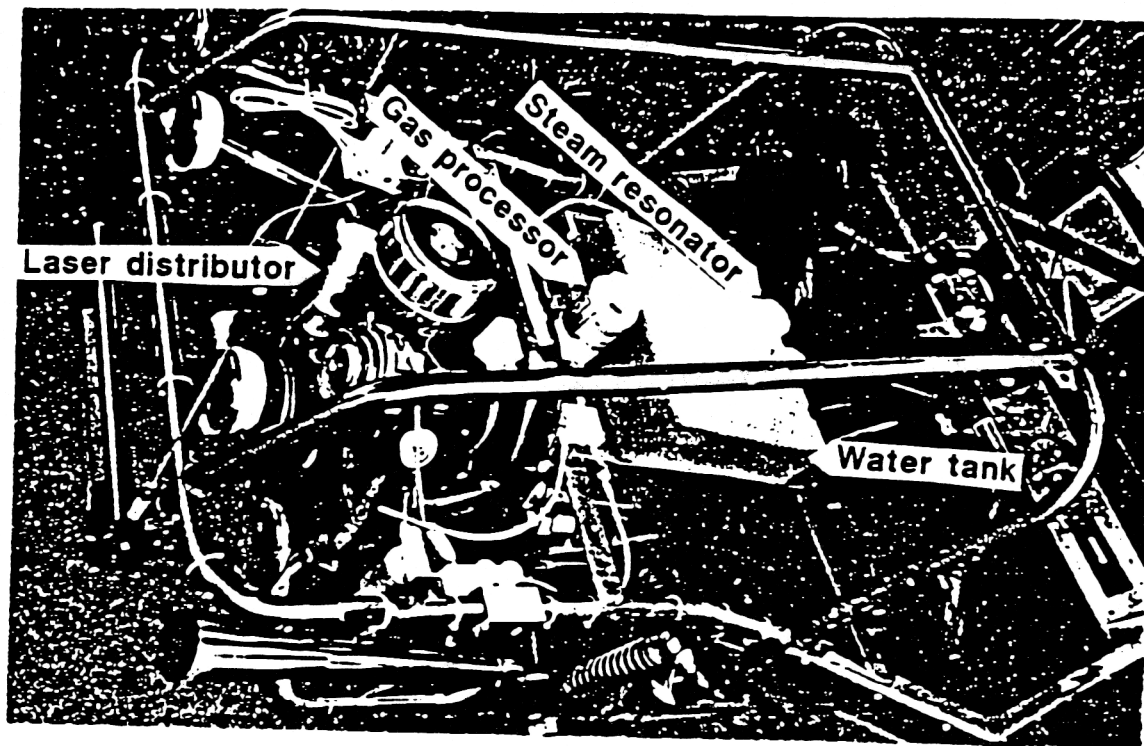

Figure 13. The 'Dune Buggy'

### APPLICATIONS

General. In its current state of development, which is to a preproduction engineering standard, WFC technology can provide a safe, economical and pollution free source of universal energy for all internal combustion petrol or diesel engines of up to 400 bhp. In addition it can readily be adapted to gas turbines (both marine and aerial) to desalination plants, home heating boilers and industrial furnaces. A Dublin food processing company is now, with Irish Government support, manufacturing a water fuelled furnace under licence from Meyer. When WFC technology reaches its full production stage, Meyer intends to market a range of conversion kits.

Given some conventional engineering development, WFC technology could be applied to very much higher powers, such as electricity generating plants (both fossil and nuclear fuelled), slow speed diesels, and space rockets. It could also provide both the propellants and the explosives for many types of weapons.

In all these cases energy would be in the form of hydrogen, obtained from the dissociation of water, coupled with ZPE itself through energy enhancement.

Meanwhile Meyer has a further development in hand which he calls 'Hyperdrive'.

### HYPERDRIVE. [12]

This new development does not require the generation of hydrogen and its subsequent combustion. It applies the energy, made available electrically from high voltage pulsing of the ZPE, directly to the generation of a water jet. It does not require an engine and has no moving parts. The power level is governed, as before,

## WATER AS FUEL

by the applied voltage. Direction is controlled by feeding the jet through manoeuvring nozzles such as those fitted to Harrier v/stol aircraft or space rockets. It is thus of special significance to marine transport.

### APPLICATION OF WFC TO MARINE TRANSPORT

**Existing Vessels.** With the application of a straightforward and inexpensive conversion kit, the present engines of these vessels could be modified to run on hydrogen extracted from the water on which they float. All auxiliary machinery, powered lifeboats etc could be similarly fuelled. The use to be made of redundant fuel tanks, pumps and heaters etc would be a matter of choice.

**Vessels Designed for Water Fuel.** As these would be designed from the outset to run their existing machinery on hydrogen, any space or deadweight which would previously have been devoted to fuel etc could usefully be reallocated by design. Performance, especially speed, need not have to take account of endurance.

**Vessels Designed for Hyperdrive.** These would be subject to radically new design to accommodate the Hyperdrive power units, including the electrical plant, and manoeuvring nozzles. No propulsion machinery, propellers, rudders, stabilizers, hydroplanes or fuel pumps, heaters etc. would be required. These vessels would be considerably cheaper than conventional vessels to build and run. Auxiliary machinery and powered lifeboats would probably have to be run on their own hydrogen plants. A possible configuration might include four self contained hyperdrive units, two main ones aft and two smaller ones for'ard. They might well be made readily detachable for refitting.

**Cargo Submarines.** The advent of hyperdrive could allow the case for cargo submarines to be reopened. The advantages of such vessels are; first, independence of the weather, hence increased reliability of schedules; second the fact that below a depth of about 100 metres less power is required for speeds of over 20 knots; and third, given a closed cycle engine, advantage could be taken of some very much shorter trade routes under the Arctic ice cap. See Figure 14.

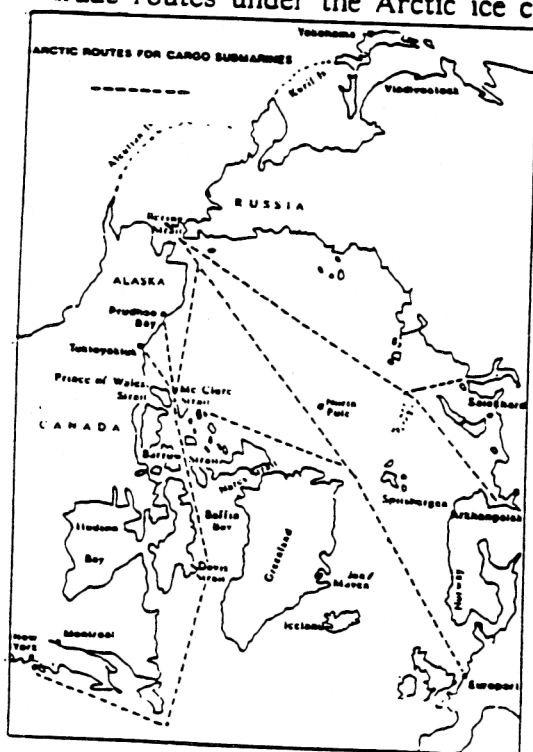

Examples of n.miles saved by Arctic Routing compared with shortest alternative

Trip	n.miles	Alternative
Yokohama ) New York )	2,200	Panama
Yokohama ) Europort )	4,900	Suez
S. Francisco ) Europort )	1,700	Panama
Manila ) Europort )	2,200	Suez
Sydney ) Europort )	1,800	Suez
Vladivostock ) Arkhangelsk )	750	Coastal in summer

Figure 14. Sub-Arctic Ice Routeing.

## WATER AS FUEL

Seasonal ice coupled with the shallowness of the water restrict submarine passage through the Bering Strait to August and September. However, given commercial demand it is possible that this restriction could be eased.

Other trading opportunities lie amongst the considerable mineral deposits in the Queen Elizabeth Islands off northern Canada from where under ice submarine passage eastwards would not be affected by conditions in the Bering Strait.

The possibility of exploiting these advantages commercially has been studied extensively, notably by General Dynamics [13] on behalf of the US government. Scores of conceptual designs have been suggested which offered speeds of up to 60 knots and deadweights of up to 500k tons. An example of an advanced tanker design suggested in the US in 1973 is shown in figure 15.

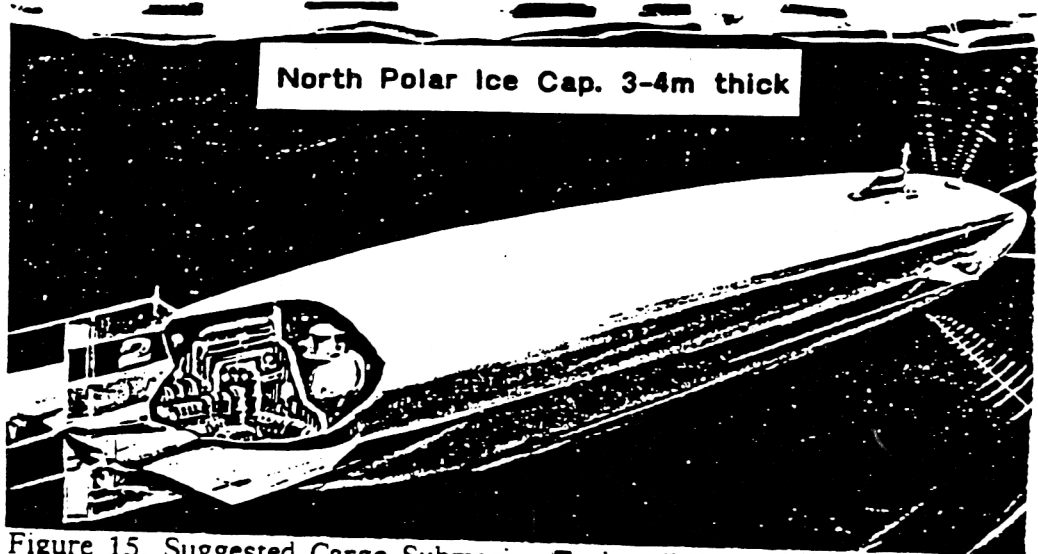

Figure 15. Suggested Cargo Submarine Tanker (US. 1973). Kummerman [14] Disp. 370,000t, speed 18kts, L. 311m, B. 51.8m, D. 27.5m, Nuclear Power 55,000 kw. Regardless of their size or projected performance, all these vessels were judged to be uneconomical and their nuclear plants would have barred them from commercial ports. However, given hyperdrive, these disadvantages would no longer apply and an illustration of such a possible future cargo submarine is shown in Figure 16.

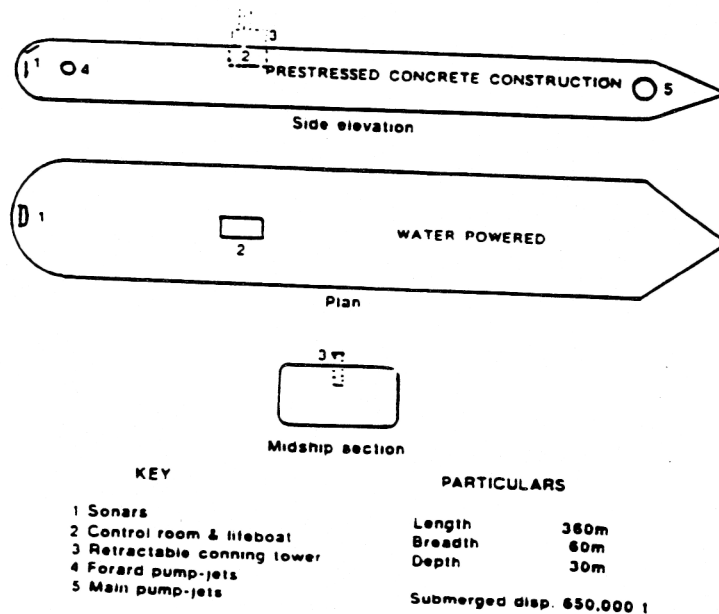

Figure 16. Projected Hyperdrive Cargo Submarine

## WATER AS FUEL

**Water Refuelling of Aircraft.** Aircraft which can fly low over water, notably helicopters, but also including certain fixed wing aircraft, could readily be adapted to include water scoops in the same way as French Riviera fire-fighting aircraft are now fitted for replenishing their water tanks. The endurance of aircraft so fitted would not be restricted by the capacity of their water fuel tanks.

### THE POTENTIAL BENEFITS OF WFC TECHNOLOGY

**Elimination of Fossil Fuel Pollution.** This would apply both locally and globally. In urban areas, such as Los Angeles, Athens, Tokyo and many other cities, pollution is an increasingly serious and apparently insoluble problem. Similarly prevailing weather patterns are said to spread pollution internationally and at the Rio de Janeiro conference concern was expressed about harmful damage being done to the World's ecosystem. Meanwhile vast resources are being expended on partial palliatives such as desulphurisation plants for power stations and the elimination of CFCs.

**Elimination of Accidental Nuclear Fall Out.** The effects of the Chernobyl nuclear disaster in April 1986 are still apparent in Wales and Scotland. The Russian nuclear power industry comprises scores of reactors which are reported now to be dangerously out of date and decrepit. There are about 50 such plants within about 10 miles of the Kremlin. A massive disaster threatens which demands immediate action and substitution by WFC power plants as soon as possible.

**Elimination of Nuclear Power.** The hazards and expense of nuclear power both at sea and on land, not forgetting massive problems over the disposal of nuclear waste and spent reactors, could be mitigated and eventually eliminated.

**Cost Savings in Energy Production.** Huge financial savings could be made over the research, production and distribution of almost all current forms of energy. (Hydro-electric and geo-thermal plants excepted).

**Cost Savings in Energy Consumption.** According to 'The Economist's 'Vital World Statistics' the World's total energy consumption in 1987 amounted to about 9.6 billion tons of coal equivalent. In 1990 the marine industry, according to the OECD, bought about 100M tons of bunker fuel, costing at today's prices about \$10B. The cost of marine transport could be further reduced as vessels make better use of the weight and space currently taken up by their fossil fuel arrangements.

**The Developing World.** The most pressing and extensive need of the developing world is energy, especially for clean water and transport as necessary conditions of improvement of food production, infrastructure and health.

**Defence.** This factor is two edged. On one hand many weapons and vehicles, whether land sea or air based, would be cheaper, safer and more economical to run. On the other hand these factors could well encourage potential troublemakers. It will therefore be essential, presumably under the auspices of the UN, for peace-keeping and peace-making forces to be sufficiently well armed to deter offensiveness.

### POSSIBLE ADVERSE IMPLICATIONS OF WFC TECHNOLOGY

**Reaction of Current Energy Interests to Threat of Displacement.** Vast resources have been committed in people and money to develop, promote and maintain whole energy industries in the fields of coal, gas, oil, and nuclear power. These investments cannot sensibly be closed down precipitately without causing major disruption and unrest. In several areas, such as the Middle East, Central America and Indonesia, national economies have become heavily dependent on national sources of fossil fuel. Consequently whole areas of the world could well become

## WATER AS FUEL

politically destabilised. Such a prospect, together with the natural concern of energy producers, could well threaten the introduction of WFC technology, as has frequently been foreshadowed during recent years by death threats and several proffered multi-million dollar inducements.

**Desalination.** Massive desalination of sea water could give rise to an excessive concentration locally of brine. Remedies need to be identified and applied.

### COUNTER ARGUMENTS TO THREATS AGAINST WFC

The following arguments could usefully be deployed :-

- a. The World's energy demands are increasing especially because the World's population, now about 10 billion, is forecast to double during the next century. Existing sources of energy should therefore be maintained so far as solutions to the pollution and nuclear problems allow.
- b. Fossil fuels are likely to be exhausted within the next century.
- c. The pollution problem needs urgent solutions.
- d. There is a serious and increasing risk of major accidents amongst many nuclear power stations.
- e. It may well take several decades before the application of WFC technology becomes significant.
- f. There are more constructive uses, such as fertilizers and plastics, for fossil products than just burning them. It is possible that new fossil products could attract higher prices than are now obtainable for fuel.
- g. WFC offers major global benefits, not least for the Developing World where competition for scarce resources causes civil war and starvation. The need is urgent. Plentiful free energy should provide such widespread economic benefits as substantially to reduce future threats to World peace.
- h. With the exception of the urgent action needed to deal with pollution and dangerous nuclear power plants, there should be enough time to make reasonably orderly adjustments to the World's current energy supply industries.

### CONCLUSIONS

#### General

- a. WFC Technology offers a real prospect of a universal, ecologically friendly, economical and inexhaustible source of energy.
- b. Its introduction would solve all the pollution problems now caused by fossil and nuclear fuels.
- c. WFC technology would greatly benefit the world's economy as a whole. In the developing world, such tensions as civil wars and starvation, brought about by competition for scarce resources, could be significantly eased.
- d. Weapons would be cheaper and hence tend to proliferate. This could result in increased threats to world peace. The UN would have to be prepared to provide adequate safeguards.

## WATER AS FUEL

e. Major opposition must be expected to the introduction of WFC technology because of the threat it appears to pose to powerful vested interests and, in certain areas, political stability. There are powerful arguments for countering such opposition.

### Impact on Marine Industries

- a. As vessels would be floating on their own fuel, propulsion and other machinery in existing vessels should be converted to WFC technology as soon as possible. This would save all fuel costs, (except lubricants) amounting to about 30% of total running expenses. In many cases it should be possible to make further gains by putting existing bunker spaces and fuel facilities to better use.
- b. Designs for new vessels should be modified as soon as possible both to include hydrogen fuelled conventional machinery and to design out, to commercial advantage, the need for bunkers and associated pumps, heaters etc.
- c. There are major opportunities, especially in the marine field, for collaboration with Meyer over WFC developments for the immediate future. Potential conversion kits range from small outboard motors through, for example, auxiliary machinery and refrigeration plants to slow speed marine diesels and marine gas turbines of many thousands of horsepower.
- d. A further substantial R&D programme is required, in close collaboration with Meyer, to bring Hyperdrive into service. Considerable technology is already available amongst existing marine pump jets and the control systems installed in aircraft and space vehicles.
- e. More radical designs for vessels and submarines of all sizes should now be initiated to incorporate Hyperdrive with its elimination of the need for conventional propulsion machinery, propellers, rudders, stabilizers and hydroplanes.
- f. Consideration should be given to the introduction of cargo submarines, powered by Hyperdrive, and constructed out of a new form of concrete material.

## WATER AS FUEL

### REFERENCES

- 1 Meyer, Stanley A. Hydrogen Fracturing Process. Memo WFC 420. Grove City Ohio. 1990 ©Stanley Meyer.
2. Maxwell, James Clerk. A Treatise on Electricity & Magnetism. 1873 Paperback New York 1954, Vol 2 p.472 & 473.
3. King, Moray.B. Tapping the Zero-Point Energy. Provo,Utah 1989. ©King,p158
4. Prigogine. Ilya and Stengers, Isabelle. Order out of Chaos. New York 1984. Chapter IX.
5. King,Moray B. ibid.1989. Electrolytic Fusion: A Zero-Point Energy Coherence?
6. Huber. J. Phenomena of the Free Energy in Nature and Technology. *raum&zeit* 49/91, Jan/Feb 1991.
7. Davidson, John. The Secret of the Creative Vacuum, chapter 11. C.W.Daniel 1989
8. Johnson. Gary L. Kansas State University, 'Electrically Induced Explosions in Water' Johnson's description of his technology has much in common with WFC.
9. Meyer, Stanley A. Atomic Energy Balance of Water. Memo WFC 424. Grove City, Ohio 1991. ©Stanley A.Meyer.
10. Prigogine. Ilya and Stengers, Isabelle. Order out of Chaos. New York 1984. Chapter IV.
11. Meyer, Stanley A. Water Fuel Injector. Memo WFC 425. Grove City, Ohio 1992. © Stanley A.Meyer.
12. Meyer, Stanley A. Hyperdrive. Memo WFC 455/455DA. Grove City,Ohio 1991. ©Stanley A.Meyer.
13. General Dynamics Corporation. Summary of a Feasibility Study on Submarine Tankers.1958.
14. Kummerman Foundation. Ships and Shipping of Tomorrow 1983. p.108.

4th July 1993



# SCIENCE EXPLAINED

The World of Science in Everyday Life

Colin A. Ronan, General Editor

A HENRY HOLT REFERENCE BOOK  
HENRY HOLT AND COMPANY  
NEW YORK

# Contents

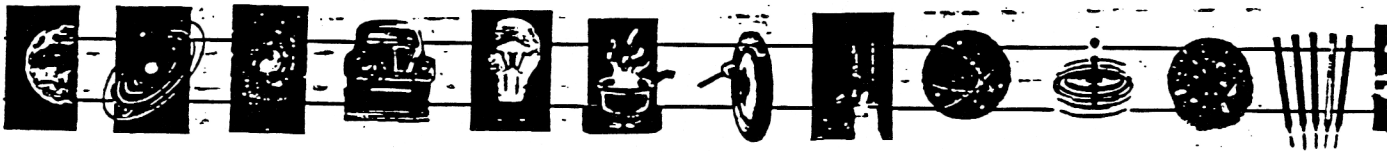

A Henry Holt Reference Book  
Henry Holt and Company, Inc.  
Publishers since 1866  
115 West 18th Street  
New York, New York 10011

Henry Holt® is a  
registered trademark of  
Henry Holt and Company, Inc.

Copyright © 1993 by  
Marshall Editions Developments Ltd.  
All rights reserved.

Library of Congress  
Cataloging-in-Publication Data  
Science explained: the world of science  
in everyday life / general editor,  
Colin A. Roman. — 1st ed.  
p. cm. — (Henry Holt reference book)  
I. Science—Miscellaneous—Popular works.  
II. Series.  
I. Roman, Colin A.  
Q173.S42 1993 93-15439  
500—dc20 CIP  
ISBN 0-8050-2551-0

Henry Holt Books are available for special  
promotions and premiums. For details  
contact: Director, Special Markets.

First Edition—1993

Conceived, edited and designed by  
Marshall Editions Ltd., London  
Printed and bound in Italy by  
New lateritho SpA, Milan  
Origination by Scantrans Pte, Singapore  
Filmsetting supplied by  
orchester Typesetting Group Limited

All first editions are printed on acid-free paper. =

10 9 8 7 6 5 4 3 2 1

Project editor Jon Kirkwood  
Art editor Marnie Searchwell  
Assistant editor Heather Magrill  
DTP editor Mary Pickles  
Copy editors Lindsay McTague  
Maggie McCormick  
Picture editor Zilda Tandy  
Picture research Judy Lehane  
Elizabeth Loving  
Researchers Helen Burridge  
Jon Richards  
Contributors David Burnie  
Chris Cooper  
John Farndon  
Steven Parker  
Robin Scagell  
Consultant Dr. Phil Whitfield  
Editorial director Ruth Binney  
Production Barry Baker  
Janice Storr  
Nikki Ingrain

*Previous page clockwise from top  
lifting a balloon with hot gases: atoms set  
free; energy's endless flow in a car trip;  
looking inside the brain: head office;  
a plant with a strange sense - touch.*

*Overleaf clockwise from top  
rocky neighbors: sister Earth and brother  
Mars; modeling reality in a virtual  
world; power in your pocket from a battery  
generating electricity; the photon and the  
flower - color from the atomic paintbox;  
plants gathering light for life.*

## Foreword 7

## Introduction 8

## Space

Introduction 11  
Our place in space 12  
Land, sea, and air 14  
Origins of life 16  
The struggle for survival 18  
A place to live 20  
Our local star 22  
The giver of life 24  
Earth's rocky neighbors 26  
Great balls of gas 28  
Planetary attendants 30  
Space debris 32  
Systems of stars 34  
How stars are born 36  
The dying light 38  
Black holes 40  
Creation of the cosmos 42  
The unfolding universe 44

## Energy

Introduction 47  
Making things move 48  
Simple machines 50  
Machines in motion 52  
What is pressure? 54  
Working under pressure 56  
Energy's endless flow 58  
Earth's energy store 60  
Energy without limit 62  
Harnessing energy 64  
Sparks and attractions 66  
Generating electrical energy 68  
The energy spectrum 70  
Visible energy 72  
The light of science 74  
Beyond violet 76  
Over the rainbow 78  
A matter of degree 80  
Heating up 82  
Sound: vibrant energy 84  
Good vibrations 86  
Sound effects 88  
Falling for gravity 90  
Defying gravity 92

# ► The intimate bonds

*Molecules are made when atoms become bonded together. But just what is it that makes these bonds?*

Atoms seem unlikely partners. Their electron clouds make them negatively charged on the outside. Since like charges repel, atoms might be expected to repel each other. The key to bonding lies in the atom's electron shell structure.

One way bonding can happen is by the sharing of electrons between atoms with one or more electrons "missing" from their outer shells. This process is called covalent bonding and happens between the atoms of elements called the non-metals and transition metals in the periodic table.

When two such atoms meet, the attraction of the nucleus of each atom is strong enough to draw an electron (or electrons) from the other atom into its orbit to fill it up. Hydrogen atoms each have a single electron so when two hydrogen atoms meet, their electron clouds intermingle and they share electrons, as if each had the full two. This is why hydrogen atoms usually go around in pairs.

Covalent compounds are formed when two or more different atoms share electrons in this way. For instance, oxygen has two gaps in its outer shell, and in the compound water an oxygen atom shares two of its six electrons with two hydrogen atoms. In return it borrows one from each hydrogen atom, so all have full outer shells.

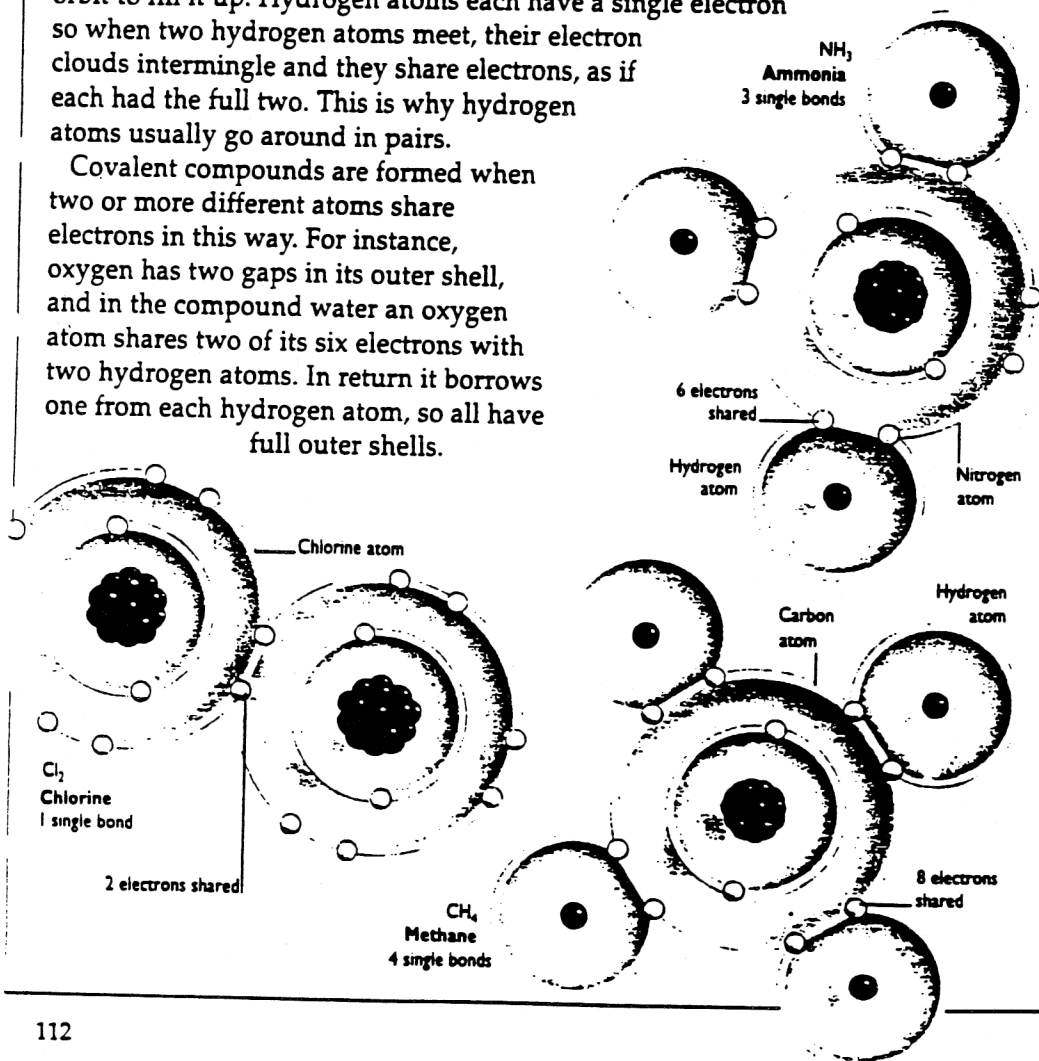

*Plants need nitrogen to grow, but fetch it from air because covalently bonded nitrogen is stable and unreactive. Instead, plants get it from nitrogen compounds in the soil. One such compound is ammonia (above left), a covalent molecule of one nitrogen and three hydrogen atoms. A fertilizer, it dramatically boosts crop yields — especially in nitrogen-poor soils.*

*All chlorine molecules share one electron each, making a single bond (far left). Oxygen molecules share two, making a double bond. Carbon dioxide, for example, forms two double bonds with oxygen atoms. Like many other compounds, carbon-based methane (left) is a gas because covalent bonds are so strong. In solids and liquids, the same links that hold solids and liquids together also hold them together.*

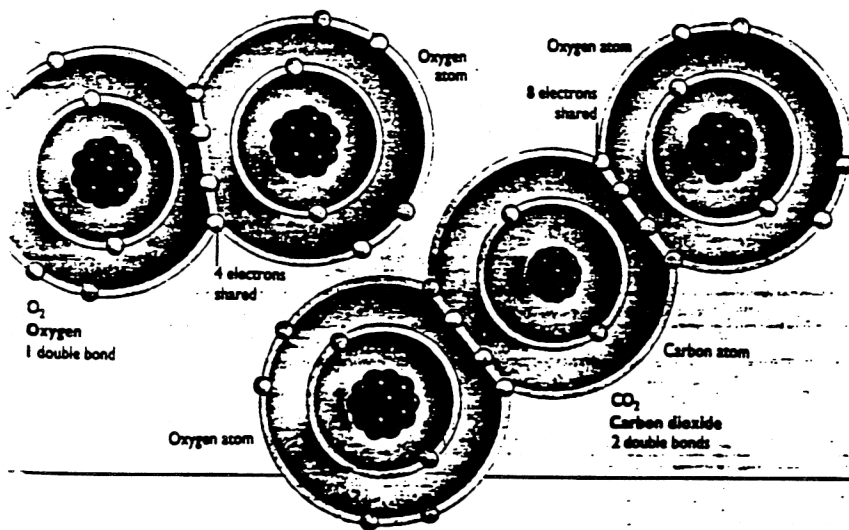
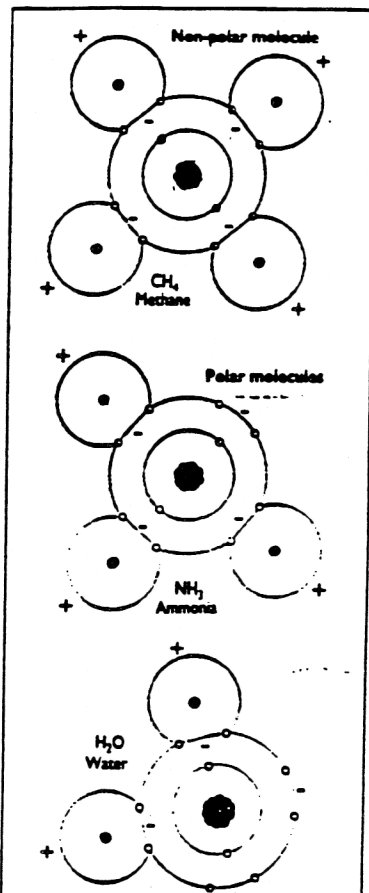

**POLAR MOLECULES**

If, when atoms share electrons, the nucleus of one atom is larger than the other, it draws electrons nearer to it. This is called a polar bond. In the carbon-hydrogen bonds in methane (top), the electrons are drawn nearer to carbon than hydrogen. In polar molecules, such as ammonia and water (above), not just single bonds are polarized but the whole molecule, because one end is more negatively charged than the other.

- See also
- ▶ **ATOMS AND MATTER**  
Inside the atom 104/105
- ▶ The key to behavior 106/107
- ▶ Classifying the elements 108/109
- ▶ Heated reactions 118/119
- ▶ What's the solution? 122/123
- ▶ Water: the unique molecule 124/125
- ▶ Carbon's vital links 130/131
- ▶ Compounds à la carte 134/135



- ▶ **LIFE**  
King carbon 150/151
- ▶ Light for life 154/155
- ▶ The microscopic factory 174/175

# Attraction of opposites

*Despite their different characteristics, atoms of metals and non-metals can be extremely attractive to each other.*

Metals and non-metals can bond together by transferring electrons in what is called an ionic bond. Anything from individual molecules to giant crystal networks can be linked up this way when atoms exchange electrons.

When the metal sodium and non-metal chlorine atoms meet, for instance, they may combine to form sodium chloride, or common salt. A chlorine atom has seven electrons in its outer shell, one short of the stable eight of inert gases. A sodium atom has an outer shell with just one electron in it above a "full" shell of eight. As they meet, the sodium's "spare" electron migrates to the chlorine, giving both atoms a full eight in their outer shells. This makes the chlorine negatively charged, since it now has an extra negatively charged electron, and the sodium positively charged, since it has "lost" one electron.

The charge on the atoms, or ions, is the key to ionic bonds. Opposite charges attract, so negative chlorine ions (anions) and positive sodium ions (cations) are drawn to each other and bond together, arranging themselves into salt crystals.

Ionic or electrovalent bonds can form like this whenever chemicals react together to make ions. Metal atoms with "spare" electrons can lose them to form cations; non-metal atoms lacking electrons can gain them to form anions. When magnesium in fireworks burns, it gives the two electrons in its outer shell to oxygen, which has six electrons in its outer shell, to form magnesium oxide.

Ionic crystals such as salt are fairly strong, but dissolve easily in water. When this happens, the bonds between the ions weaken, and they separate to drift

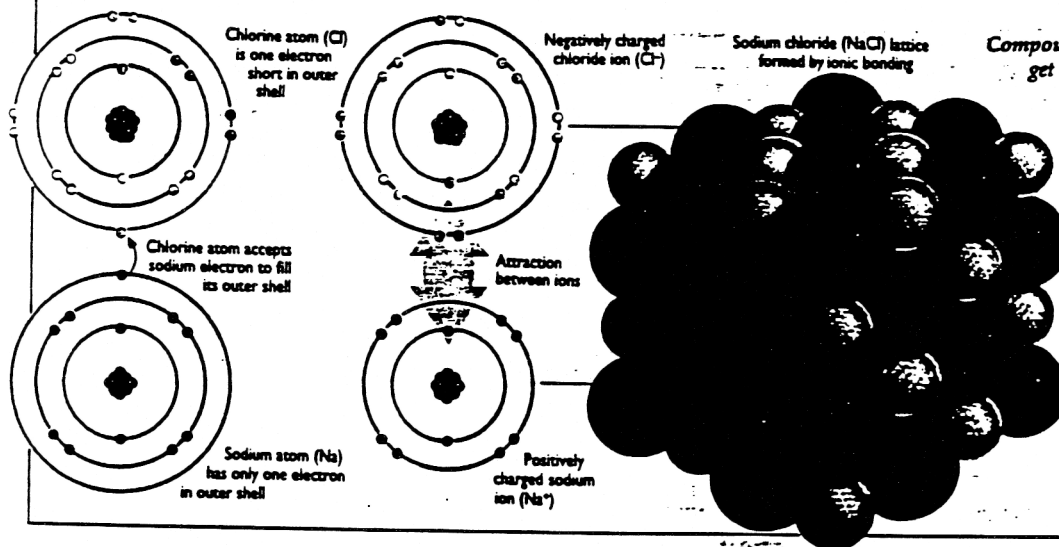

Compounds formed when metals and non-metals get together rely on electron exchange. The bond formed is called an ionic bond because after the electron exchange, the atoms the elements involved become ions - charged particles. In common salt (sodium chloride), a metal with one electron in its outer shell, donates the electron to non-metal chlorine, which has one short of the full complement of eight electrons in its outer shell. Solid salt is a crystal, and the ions stack up in a regular pattern or lattice.

Rock salt, found underground, is the source of most of our common salt. The most familiar use of salt is to flavor food, but it is also used in road manufacture, for keeping roads free of ice in winter, and as a source of chlorine.

# Chemistry

by  
*Harold D. Nathan, Ph.D.*

Series Editor  
Jerry Bobrow, Ph.D.



**Cliffs Notes**  
INCORPORATED  
LINCOLN, NEBRASKA 68501

# ***Cliffs Quick Review Chemistry***

***The Cliffs Notes logo, the names "Cliffs," "Cliffs Notes," and "Cliffs Quick Review," and the black and yellow diagonal stripe cover design are all registered trademarks belonging to Cliffs Notes, Inc., and may not be used in whole or in part without written permission.***

**FIRST EDITION**

© Copyright 1993 by Cliffs Notes, Inc.

***All Rights Reserved  
Printed in U.S.A.***

**ISBN 0-8220-5318-7**

and you can interpolate this value in the first column of the previous chart to find that such a bond would be about 4% ionic and 96% covalent, which is virtually a pure covalent bond.

**Problem 11.** Use the chart of electronegativity and the chart of bond types to interpret the bonding in magnesium chloride,  $\text{MgCl}_2$ .

### Other Bonds

A polar bond between hydrogen and a nonmetallic element frequently results in a unique secondary bonding between the hydrogen and another negative ion. Such secondary bonding is called a **hydrogen bond** and is much weaker than the primary polar bond. Let's use a water molecule as an example because the electronegativity difference of hydrogen and oxygen is 1.4, indicating that those elements form a polar bond of about 36% ionic character.

#### POLAR BONDS IN $\text{H}_2\text{O}$

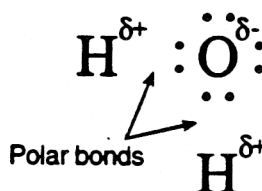

■ Figure 26 ■

The polarity of the hydrogen-oxygen bond leaves the hydrogen atom with its positive nucleus unshielded by any electrons. This positive charge can then electrostatically attract other negative charges, either anions of dissolved salts or the oxygen ( $\text{O}^{\delta-}$ ) of other water molecules. In seawater, rich in  $\text{Na}^+$  cations and  $\text{Cl}^-$  anions, the hydrogen attracts the chloride forming hydrogen bonds:



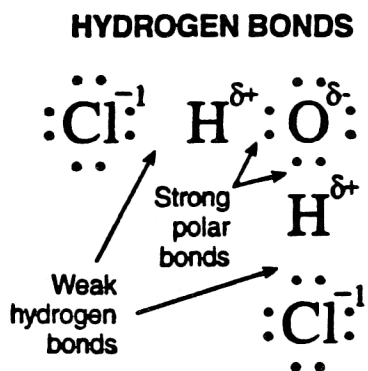

■ Figure 27 ■

This ability of water to form hydrogen bonds explains its unusual property of dissolving many substances.

A final type of bond that you should know about is the **metallic bond** in which electrons move freely among many atoms. The free metals, uncharged metal atoms uncombined with nonmetallic anions, allow this behavior because several electron orbitals usually exist at similar energy levels. An electron is not permanently associated with a single nucleus but may migrate from one to another. This movement of electrons explains why metals are characteristically lustrous, malleable, and highly conductive of heat or electricity.

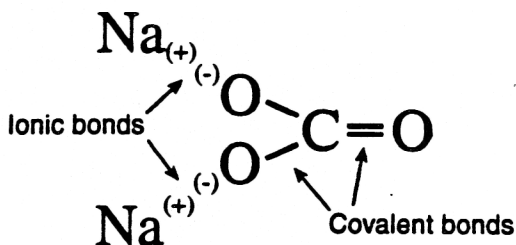
BONDING IN Na<sub>2</sub>CO<sub>3</sub>

■ Figure 51 ■

The sodium carbonate is a strong electrolyte and dissociates completely to 3 ions when placed in water.

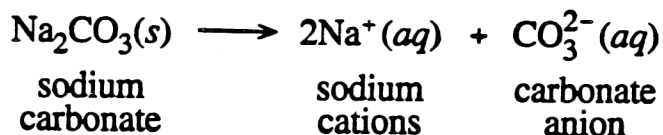

The carbonate anion is held intact by its internal covalent bonds.

Substances containing polar bonds of intermediate character commonly undergo only partial dissociation when placed in water; such substances are classed as *weak electrolytes*. An example is boric acid:

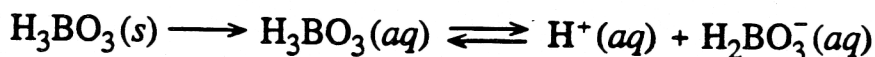

A solution of that acid is dominated by molecules of H<sub>3</sub>BO<sub>3</sub> with relatively scarce H<sup>+</sup> and H<sub>2</sub>BO<sub>3</sub><sup>-</sup> ions. Make sure you grasp the difference between this case and the previous example of the strong electrolyte Na<sub>2</sub>CO<sub>3</sub>.

Acids and bases are usefully sorted into *strong* and *weak* classes, depending on their degree of ionization in aqueous solution. Notice that these terms are not defined by the pH of the solution.

The dissociation of any acid may be written as an equilibrium reaction:



where A denotes the anion of the particular acid. The concentrations of the three solute species are related by the equilibrium equation

$$\frac{[\text{H}^+][\text{A}^-]}{[\text{HA}]} = K_a$$

where  $K_a$  is the **acid ionization constant** (or merely acid constant). Different acids have different  $K_a$  values—the higher the value, the greater the degree of dissociation of the acid in solution. Strong acids, therefore, have higher  $K_a$  than do weak acids.

The following chart gives acid ionization constants for several familiar acids at 25°C. The values for the strong acids are not well defined. Examine the column labeled "Ions" and see how every acid yields a hydrogen ion and a complementary anion in solution.

**SOME COMMON ACIDS**

Acid	Formula	Ions	$K_a$	
Hydrochloric	HCl	H <sup>+</sup> Cl <sup>-</sup>	10 <sup>7</sup>	} strong acids
Chloric	HClO <sub>3</sub>	H <sup>+</sup> ClO <sub>3</sub> <sup>-</sup>	10 <sup>3</sup>	
Sulfuric	H <sub>2</sub> SO <sub>4</sub>	H <sup>+</sup> HSO <sub>4</sub> <sup>-</sup>	10 <sup>2</sup>	
Nitric	HNO <sub>3</sub>	H <sup>+</sup> NO <sub>3</sub> <sup>-</sup>	10 <sup>1</sup>	
Sulfurous	H <sub>2</sub> SO <sub>3</sub>	H <sup>+</sup> HSO <sub>3</sub> <sup>-</sup>	1.5 × 10 <sup>-2</sup>	} weak acids
Phosphoric	H <sub>3</sub> PO <sub>4</sub>	H <sup>+</sup> H <sub>2</sub> PO <sub>4</sub> <sup>-</sup>	7.5 × 10 <sup>-3</sup>	
Acetic	CH <sub>3</sub> COOH	H <sup>+</sup> CH <sub>3</sub> COO <sup>-</sup>	1.8 × 10 <sup>-5</sup>	
Carbonic	H <sub>2</sub> CO <sub>3</sub>	H <sup>+</sup> HCO <sub>3</sub> <sup>-</sup>	4.3 × 10 <sup>-7</sup>	
Boric	H <sub>3</sub> BO <sub>3</sub>	H <sup>+</sup> H <sub>2</sub> BO <sub>3</sub> <sup>-</sup>	7.3 × 10 <sup>-10</sup>	

## History In The Making

### WFC Publications Available

**The Birth of New Technology ....** WFC Technical Brief Explaining the Hydrogen Fracturing Process on how to use "Water" as a new fuel-source. US \$35 plus \$5 postage or \$10 for foreign mailing. U.S. Currency Only.

**WFC Dealership Sales Manual**  
Explaining Water Fuel Cell business format and general overview of WFC Tech-base and related spin-off development (s) and included therein WFC Profit Sharing Certificate Preliminary Prospectus. US \$30 plus \$5 postage or \$10 foreign mailing. U.S. Currency Only.

**WFC International Independent Test-Evaluation Report-Binder**  
Listing of independent "Publication of Reports" conducted by various research laboratories World-wide confirming WFC "Technology of Inventions." US \$35 plus \$5 postage in U.S. or \$10 for foreign mailing. U.S. Currency Only.

**WFC U.S. Patent Grants "Publication of Release"**  
Listing WFC U.S. Patent Grants "Publication of Release" in a binder. U.S. \$65 plus \$12 postage in U.S. or \$22 for foreign mailing. U.S. Currency Only.

**Historical WFC International News "Releases of Review"**  
Listing WFC International News Releases "out of circulation" mailers denoting public notice of WFC Development and business activities. US \$30 plus \$5 postage in U.S. or \$10 for foreign mailing. U.S. Currency Only.

**WFC International News Release**  
Yearly news update on Water Fuel Cell business and product development activities World-wide. US \$5 per copy plus \$2.50 postage in U.S. or \$4.50 for foreign mailing. U.S. Currency Only.

**WFC Video Tape**  
Titled "The Birth of New Technology ... Extraordinary Science Talk." US \$30 plus \$5 postage in U.S. or \$7 for foreign mailing. U.S. Currency Only.

**\* \* WFC Dealership Information**  
To attend a WFC Dealership Seminar, please call Charles Holbrook (1-614-335-2153) before 7am or after 7pm EST or Fax 1-614-871-8075 for scheduling information, or mail request to Water Fuel Cell, 3792 Broadway, Grove City, Ohio 43123 to obtain a WFC Dealership Seminar Authorization Pass.

**\* \* WFC Employment Opportunities**  
Please send employment Resumes and related information to Dr. Russell E. Fowler, WFC Executive Director Personnel and Education Department, 401 Rick Lane, Indianapolis, IN 46217, Tel/Fax 1-317-787-5226 between 7pm - 9pm Est weekdays only.

Requested WFC Information not to be used for manufacturing purposes

### Water Fuel Cell

3792 Broadway  
Grove City, Ohio 43123  
Tel. 1-614-871-4173; Fax 1-614-871-8075

